

UPQ-D1 Wide Coverage Loudspeaker

UPQ-D2 Narrow Coverage Loudspeaker

UPQ-D3 Wide Symmetrical Coverage Loudspeaker



***Keep these important operating instructions.
Check www.meyersound.com for updates.***

© 2019

Meyer Sound. All rights reserved.

UPQ-D1/D2/D3 Operating Instructions, PN 05.291.005.01 A





The contents of this manual are furnished for informational purposes only, are subject to change without notice, and should not be construed as a commitment by Meyer Sound Laboratories Inc. Meyer Sound assumes no responsibility or liability for any errors or inaccuracies that may appear in this manual. Except as permitted by applicable copyright law, no part of this publication may be reproduced, stored in a retrieval system, or transmitted, in any form or by any means, electronic, mechanical, recording or otherwise, without prior written permission from Meyer Sound.

CAL, Compass Go by Meyer Sound, Compass RMS, Intelligent AC, LEO-M, LEOPARD, LYON, MAPP, RMS, UltraSeries, and all alphanumeric designations for Meyer Sound products and accessories are trademarks of Meyer Sound. Meyer Sound, Compass, Constellation, Galileo, LEO, QuickFly, SIM, Spacemap, Thinking Sound, TruPower, TruShaping, and U-Shaping, are registered trademarks of Meyer Sound Laboratories Inc. (Reg. U.S. Pat. & Tm. Off.). All third-party trademarks mentioned herein are the property of their respective trademark holders.

IMPORTANT SAFETY INSTRUCTIONS

These symbols indicate important safety or operating features in this booklet and on the frame or chassis:

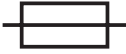
SYMBOLS USED

				
Dangerous voltages: risk of electric shock	Important operating instructions	Replaceable Fuse	Protective earth ground	Hot surface: do not touch
Gefährliche Spannungen: Stromschlaggefahr	Hinweis auf wichtige Punkte der Betriebsanleitung	Austauschbare Sicherung	Schutzerde	Heiße Oberfläche: nicht berühren
Pour indiquer les risques résultant de tensions dangereuses	Instructions d'utilisation importantes	Fusible remplaçable	Terre de protection	Surface chaude: ne pas toucher
Para indicar voltajes peligrosos	Instrucciones importantes de funcionamiento y/o Mantenimiento	Fusible reemplazable	Toma de tierra de protección	Superficie caliente: no tocar

1. Read these instructions.
2. Keep these instructions.
3. Heed all warnings.
4. Follow all instructions.
5. Do not use this apparatus near water.
6. Clean only with dry cloth.
7. Do not block any ventilation openings. Install in accordance with Meyer Sound's installation instructions.
8. Do not install near any heat sources such as radiators, heat registers, stoves, or other apparatus that produce heat.
9. Do not defeat the safety purpose of the grounding-type plug. A grounding type plug has two blades and a third grounding prong. The third prong is provided for your safety. If the provided plug does not fit into your outlet, consult an electrician for replacement of the obsolete outlet.
10. Protect the power cord from being walked on or pinched, particularly at plugs, convenience receptacles, and the point where they exit from the apparatus. The AC mains plug or appliance coupler shall remain readily accessible for operation.
11. Only use attachments/accessories specified by Meyer Sound.
12. Use only with the caster rails or rigging specified by Meyer Sound, or sold with the apparatus. Handles are for carrying only.
13. Unplug this apparatus during lightning storms or when unused for long periods of time.
14. If equipped with an external fuse holder, the replaceable fuse is the only user-serviceable item. When replacing the fuse, only use the same type and the same value.
15. Refer all other servicing to qualified service personnel. Servicing is required when the apparatus has been damaged in any way, such as when the power-supply cord or plug has been damaged; liquid has been spilled or objects have fallen into the apparatus; rain or moisture has entered the apparatus; the apparatus has been dropped; or when for undetermined reasons the apparatus does not operate normally.



WARNING: To reduce the risk of fire or electric shock, do not expose this apparatus to rain or moisture. Do not install the apparatus in wet or humid locations without using weather protection equipment from Meyer Sound.

PowerCON Use



CAUTION: Disconnect the mains plug before disconnecting the power cord from the loudspeaker.

English

- To reduce the risk of electric shock, disconnect the apparatus from the AC mains before installing audio cable. Reconnect the power cord only after making all signal connections.
- Connect the apparatus to a two-pole, three-wire grounding mains receptacle. The receptacle must be connected to a fuse or circuit breaker. Connection to any other type of receptacle poses a shock hazard and may violate local electrical codes.
- Do not install the apparatus in wet or humid locations without using weather protection equipment from Meyer Sound.
- Do not allow water or any foreign object to get inside the apparatus. Do not put objects containing liquid on or near the apparatus.
- To reduce the risk of overheating the apparatus, avoid exposing it to direct sunlight. Do not install the apparatus near heat-emitting appliances, such as a room heater or stove.
- If equipped with an external fuse holder, the replaceable fuse is the only item that can be serviced by the user. When replacing the fuse, only use the same type and value.
- This apparatus contains potentially hazardous voltages. Do not attempt to disassemble the apparatus. The only user-serviceable part is the fuse if so equipped. All other repairs should be performed only by factory-trained service personnel.

Deutsch

- Zur Minimierung der Gefahr eines elektrischen Schlages trennen Sie das Produkt vor dem Anschluss von Audio- und/oder Steuerleitungen vom Stromnetz. Das Netzkabel darf erst nach Herstellung aller Signalverbindungen wieder eingesteckt werden.
- Das Produkt an eine vorschriftsgemäss installierte dreipolige Netzsteckdose (Phase, Neutralleiter, Schutzleiter) anschließen. Die Steckdose muss vorschriftsgemäß mit einer Sicherung oder einem Leitungsschutzschalter abgesichert sein. Das

Anschließen des Produkts an eine anders ausgeführte Stromversorgung kann gegen Vorschriften verstossen und zu Stromunfällen führen.

- Das Produkt nicht an einem Ort aufstellen, an dem es direkter Wassereinwirkung oder übermäßig hoher Luftfeuchtigkeit ausgesetzt werden könnte, solange es sich nicht um ein Produkt handelt, dass mit der Meyer Sound Weather Protection Option ausgestattet ist.
- Vermeiden Sie das Eindringen von Wasser oder Fremdkörpern in das Innere des Produkts. Stellen Sie keine Objekte, die Flüssigkeit enthalten, auf oder neben dem Produkt ab.
- Um ein Überhitzen des Produkts zu verhindern, halten Sie das Gerät von direkter Sonneneinstrahlung fern und stellen Sie es nicht in der Nähe von wärmeabstrahlenden Geräten (z.B. Heizgerät oder Herd) auf.
- Bei Ausstattung mit einem externen Sicherungshalter ist die austauschbare Sicherung das einzige Gerät, das vom Benutzer gewartet werden kann. Verwenden Sie beim Austausch der Sicherung nur den gleichen Typ und Wert.
- Dieses Gerät enthält möglicherweise gefährliche Spannungen. Versuchen Sie nicht, das Gerät zu zerlegen. Der einzige vom Benutzer zu wartende Teil ist die Sicherung, falls vorhanden. Alle anderen Reparaturen dürfen nur von im Werk geschultem Servicepersonal ausgeführt werden.

Français

- Pour éviter tout risque d'électrocution, débranchez l'enceinte de la prise secteur avant de mettre en place le câble audio. Ne rebranchez le cordon secteur qu'après avoir procédé à toutes les connexions de signal audio
- Branchez l'enceinte sur une prise murale à deux fiches et trois conducteurs avec terre. Cette prise doit être reliée à une ligne électrique protégée par un fusible ou un court-circuit. Utiliser une prise murale de type différent crée des risques d'électrocution, et peut enfreindre des réglementations électriques locales.
- N'installez pas l'enceinte dans des endroits humides ou en présence d'eau sans utiliser d'équipements de protection adéquats fournis par Meyer Sound.
- Ne laissez pas d'eau ou d'objet étranger, quel qu'il soit, pénétrer à l'intérieur de l'enceinte. Ne posez pas d'objet contenant du liquide sur ou à proximité de l'enceinte.

- Pour réduire les risques de surchauffe, évitez d'exposer directement l'enceinte aux rayons du soleil. Ne l'installez pas à proximité de sources de chaleur, radiateur ou four par exemple.
- S'il est équipé d'un porte-fusible externe, le fusible remplaçable est le seul élément qui peut être réparé par l'utilisateur. Lors du remplacement du fusible, n'utilisez que le même type et la même valeur.
- Cet appareil contient des tensions potentiellement dangereuses. N'essayez pas de démonter l'appareil. La seule pièce pouvant être réparée par l'utilisateur est le fusible, s'il en est équipé. Toutes les autres réparations doivent être effectuées uniquement par du personnel de maintenance formé en usine.

Todas las demás reparaciones deben ser realizadas únicamente por personal de servicio capacitado de fábrica.

Español

- Para reducir el riesgo de descarga eléctrica, desconecte el aparato de la red eléctrica antes de instalar el cable de audio. Vuelva a conectar el cable de alimentación sólo después de realizar todas las conexiones de señal.
- Conecte el aparato a una toma de corriente de dos polos y tres hilos con conexión a tierra. El receptáculo debe estar conectado a un fusible o disyuntor. La conexión a cualquier otro tipo de receptáculo representa un riesgo de descarga eléctrica y puede violar los códigos eléctricos locales.
- No instale el aparato en lugares húmedos o mojados sin usar el equipo de protección contra intemperie de Meyer Sound.
- No permita que penetre agua u otros objetos extraños en el interior del aparato. No coloque objetos que contengan líquido sobre o cerca de la unidad.
- Para reducir el riesgo de sobrecalentamiento del aparato, evite exponerlo a la luz solar directa. No instale la unidad cerca de aparatos que emitan calor, como un calefactor o una estufa.
- Si está equipado con un portafusibles externo, el fusible reemplazable es el único elemento que puede ser reparado por el usuario. Cuando reemplace el fusible, use solamente el mismo tipo y valor.
- Este aparato contiene voltajes potencialmente peligrosos. No intente desmontar la unidad. La única pieza que el usuario puede reparar es el fusible si equipado con él.

CONTENTS

Important Safety Instructions	iii
Symbols Used	iii
Chapter 1: Introduction	9
How to Use This Manual	9
The UPQ-D Series Loudspeaker	9
Integrated Amplifier and Processing	10
Rig-Ready	10
Total System Approach	10
Chapter 2: Power Requirements	13
AC Power Distribution	13
AC Connectors	14
Wiring AC Power Cables	15
Voltage Requirements	15
Current Requirements	15
Intelligent AC Power Supply	16
Electrical Safety Guidelines	17
Chapter 3: Amplification and Audio Connectors	19
Audio Connectors	19
TruPower Limiting	20
On/Status LED	21
Amplifier Cooling System	21
Chapter 4: Adding Low Frequency Control	23
Adding Subwoofers by Daisy-Chaining	23
Using a Processor	23
Chapter 5: QuickFly Rigging	25
Important Safety Considerations!	25
Basic Eye Bolt Rigging	25
UPQ-D Series Rigging Accessories	26
Pole-Mounting the UPQ-D Series	26
The MYA-UPQ Mounting Yoke	26
The MPA-UPQ Array Adapter	27
Chapter 6: RMS Remote Monitoring System	31
Compass Control Software	31
RMS Module	31
Neuron ID for RMS Module	32
Resetting the RMS Module	32
Chapter 7: System Design and Integration Tools	33
MAPP System Design Tool	33
Galileo Galaxy Network Platform	34
SIM Measurement System	34

Appendix A: Meyer Sound Weather Protection	35
Weather Protection Components	36
Installation Practices	36
IP Ratings	37
Appendix B: Rain Hoods	39
Rigid Rain Hood	39
Foldable Rain Hood	40
Appendix C: UPQ-D Series Specifications	41
UPQ-D Series Acoustical, Electrical, and Physical Specifications	41
UPQ-D1/D2/D3 Loudspeaker Dimensions	44
UPQ-D1/D2/D3 with Rain hood Loudspeaker Dimensions	45

CHAPTER 1: INTRODUCTION

HOW TO USE THIS MANUAL

Make sure to read these instructions in their entirety before configuring a Meyer Sound loudspeaker system. In particular, pay close attention to material related to safety issues.

As you read these instructions, you will encounter the following icons for notes, tips, and cautions:



NOTE: A note identifies an important or useful piece of information relating to the topic under discussion.



TIP: A tip offers a helpful tip relevant to the topic at hand.



CAUTION: A caution gives notice that an action may have serious consequences and could cause harm to equipment or personnel, or could cause delays or other problems.

Information and specifications are subject to change. Updates and supplementary information are available at www.meyersound.com.

Meyer Sound Technical Support is available at:

- **Tel:** +1 510 486.1166
- **Tel:** +1 510 486.0657 (after hours support)
- **Web:** www.meyersound.com/support

THE UPQ-D SERIES LOUDSPEAKER

Meyer Sound's UPQ-D Series loudspeakers evolved from the UPQ-1P and UPQ-2P product line, optimized using the advanced amplifier and processing technology that made the LEO® family an award-winning product line. The series includes the following loudspeakers:

- UPQ-D1, which has a Constant-Q horn with -6 dB points at 80° horizontal x 50° vertical (-10 dB points at 100° horizontal x 60° vertical)
- UPQ-D2, which has a narrow symmetrical coverage and a Constant-Q horn with -6 dB points at 50° x 50° (-10 dB points at 60° x 60°)
- UPQ-D3, which has a wide symmetrical coverage and a Constant-Q horn with -6 dB points at 80° horizontal x 80° vertical (-10 dB points at 100° horizontal x 100° vertical)

All of the UPQ-D series feature:

- An innovative, highly efficient Class D amplifier with reduced current draw that reproduces any sound with linearity over a wide dynamic range
- Optimized frequency and phase response characteristics
- Lightened cabinet weight
- A redesigned cabinet that retains the original size, grille frame, and rigging options of previous UPQ products

Each UPQ-D Series loudspeaker offers extremely consistent polar response and gentle coverage rolloffs that extend uniformly out to their 10 dB points. The smooth and consistent performance of all the horns is the result of advanced computer modeling combined with meticulous research in Meyer Sound's anechoic chamber. They also exhibit remarkably consistent beamwidth in both the horizontal and vertical planes. The UPQ-D Series horns deliver uniform attenuation for all frequencies outside the specified beamwidths.

In addition to the Constant-Q horn, the loudspeakers each feature one low frequency 15-inch neodymium magnet cone driver and one 4-inch diaphragm compression driver, both designed and manufactured at Meyer Sound's Berkeley, California headquarters. The UPQ-D1 and UPQ-D3 are suitable for a range of sound reinforcement applications including as front-of-house main loudspeakers in small- to mid-sized venues, or as fill loudspeakers in larger systems.

The UPQ-D2 offers a focused beamwidth, which yields precise coverage and minimal interaction with walls and neighboring loudspeakers in arrays. This feature makes it an ideal solution for small to mid-sized venues, houses of worship, theaters, and nightclubs, as either a stand-alone loudspeaker or as part of an array.

INTEGRATED AMPLIFIER AND PROCESSING

The proprietary two-channel, class D power amplifier yields a total power output of 2250 W. Audio input routes through electronic crossover and correction filters, as well as through driver-protection circuitry. Phase-corrected processing ensures a flat acoustical amplitude and phase response, resulting in an exceptional impulse response and precise imaging.

Each amplifier channel has sophisticated limiters that are easily monitored with the limit LEDs on the unit's rear panel. The UPQ-D Series modular amplifier and processing electronics incorporate Meyer Sound's Intelligent AC™ power supply which adapts to any power voltage worldwide and provides soft turn on and transient protection. The UPQ-D Series use XLR 3-pin female input with male loop output connectors.

The optional RMS™ remote monitoring system module provides comprehensive monitoring of loudspeaker parameters from a host computer running Compass® software. An optional XLR 5-pin connector is available to accommodate both balanced audio and RMS signals.

RIG-READY

The UPQ-D1/D2/D3 loudspeakers provide extremely high power output with low distortion in vented two-way enclosures. The durable trapezoidal enclosures have a slightly textured black finish, an integral stand mount receptacle, and versatile rigging end plates. Made of heavy-duty, high-strength, corrosion-resistant 6061T6 aluminum, the end plates incorporate threaded M10 attachment points.

QuickFly® rigging options include the MPA-UPQ pickup and array plate and MYA-UPQ mounting yoke. UPQ-D Series loudspeakers are available in custom color finishes, allowing them to blend in with any environment. Weather-protected versions with treated-wood enclosures and a rain hood to safeguard the rear of the loudspeaker and connectors from the elements are also available.

 **NOTE:** Complete acoustical, electrical and physical specifications are covered in Appendix C on page 41.

TOTAL SYSTEM APPROACH

The UPQ-D Series loudspeakers integrate seamlessly with other Meyer Sound products. With compatible acoustical and performance characteristics and dedicated QuickFly rigging hardware, the UPQ-D Series loudspeakers and other Meyer Sound self-powered loudspeakers can provide everything needed to design and implement systems for optimum performance in venues of any size or shape.



TIP: Meyer Sound MAPP™ acoustical prediction software allows for quick determination of the coverage, frequency response, impulse response, and maximum linear, undistorted output of Meyer Sound loudspeakers. It also provides useful rigging information.

In addition to smooth integration with other Meyer Sound loudspeakers, the UPQ-D Series loudspeakers can be supplemented with Meyer Sound subwoofers for extended low-frequency bandwidth and headroom. UPQ-D Series systems can be deployed in combination with the 750-LFC very compact low-frequency control element (Figure 1), extending the system frequency response down to 35 Hz, or the 900-LFC compact low-frequency control element (Figure 2), which supports frequencies down to 30 Hz.



Figure 1: The 750-LFC Very Compact Low Frequency Control Element

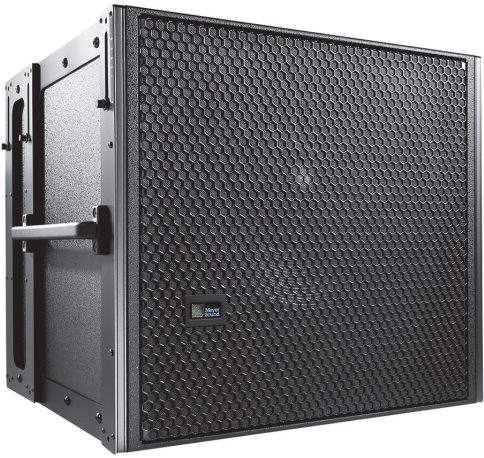

Figure 2: The 900-LFC Compact Low Frequency Control Element

The UPQ-D Series are supported by Meyer Sound's MAPP acoustical prediction program and the Galileo™ GALAXY Network Platform loudspeaker management system. After a Meyer Sound system is designed and installed, its performance can be confirmed using a SIM audio analyzer system.

CHAPTER 2: POWER REQUIREMENTS

The UPQ-D Series loudspeakers combine advanced loudspeaker technology with equally advanced power capabilities. Understanding power distribution, voltage and current requirements, and electrical safety guidelines is critical for the safe operation of the UPQ-D Series loudspeakers.

AC POWER DISTRIBUTION

All components in an audio system (self-powered loudspeakers, mixing consoles, and processors) must be properly connected to an AC power distribution system, ensuring that AC line polarity is preserved and that all grounding points are connected to a single node or common point using the same cable gauge (or larger) as the neutral and line cables.

CAUTION: Make sure the voltage received by the UPQ-D Series loudspeakers remain within their 90–264 V AC operating range. In addition, the ground line must always be used for safety reasons and the line-to-ground voltage should never exceed 250 V AC (typically 120 V AC from line to ground).

CAUTION: Before applying AC power to any Meyer Sound self-powered loudspeaker, make sure that the voltage potential difference between the neutral and earth-ground lines is less than 5 V AC when using single-phase AC wiring.

NOTE: Improper grounding of connections between loudspeakers and the rest of the audio system may produce noise or hum, or cause serious damage to the input and output stages of the system's electronic components.

120 V AC, 3-Phase Wye System (Single Line)

Line-Neutral-Earth/Ground

Figure 3 illustrates a basic 120 V AC, 3-phase Wye distribution system with the loudspeaker load distributed across all three phases and with each loudspeaker connected to a single line and common neutral and earth/ground lines. This system delivers 120 V AC to each loudspeaker.

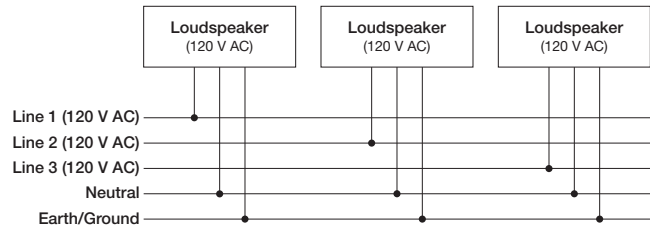

Figure 3: 120 V AC, 3-Phase Wye System (Single Line to Loudspeakers)

120 V AC, 3-Phase Wye System (Two Lines)

Line-Line-Earth/Ground

Figure 4 illustrates a 120 V AC, 3-phase Wye distribution system with each loudspeaker connected to two lines and a common earth/ground line. This configuration is possible because the UPQ-D Series tolerate elevated voltages from the ground line and does not require a neutral line. This system delivers 208 V AC to each loudspeaker.

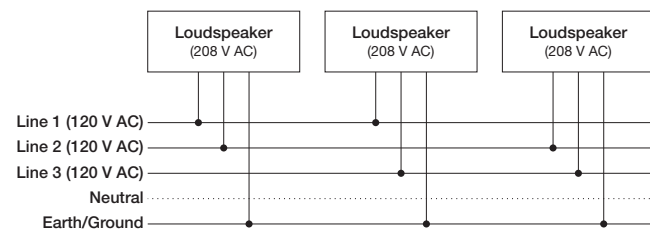

Figure 4: 120 V AC, 3-Phase Wye System (Two Lines to Loudspeakers)

TIP: The 120 V AC, 3-phase Wye system with two lines is recommended because it allows loudspeakers to draw less current than with single-line systems, thereby reducing voltage drop due to cable resistance. It also excludes the potential of varying ground to neutral voltages producing an audible hum.

230 V AC, 3-Phase Wye System (Single Line)

Line-Neutral-Earth/Ground

Figure 5 illustrates a basic 230 V AC, 3-phase Wye distribution system with the loudspeaker load distributed across all three phases and with each loudspeaker connected to a single line and common neutral and earth/ground lines. This system delivers 230 V AC to each loudspeaker.

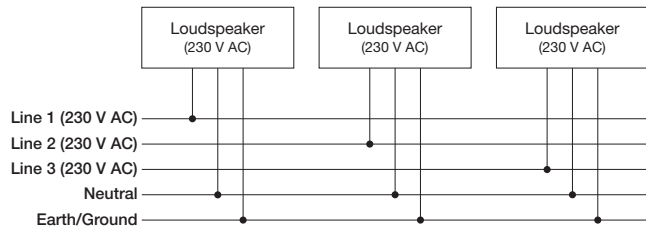

Figure 5: 230 V AC, 3-Phase Wye System (Single Line to Loudspeakers)

CAUTION: For 230 V AC, 3-phase Wye systems, never connect two lines to the AC input of a UPQ-D Series loudspeaker, as the resulting voltage would exceed the upper voltage limit (275 V AC) and will damage the loudspeaker.

AC CONNECTORS

The UPQ-D Series loudspeaker user panel includes two powerCON 20 connectors (Figure 6), one for AC Input (blue) and one for AC Loop Output (gray).



Figure 6: AC Input (Left) and AC Loop Output (Right) Connectors

AC Input (Blue)

The blue AC Input connector supplies power to a UPQ-D Series loudspeaker. The 3-conductor powerCON 20 is rated at 20 A and uses a locking connector that prevents accidental disconnections. A 10-foot AC power cable, rated at 15 A, is included with each loudspeaker. If the included AC power cable is replaced, make sure to use a cable with the appropriate power plug (on the other end) for the region where the unit will be operated. The UPQ-D Series require a

grounded outlet. To operate safely and effectively, it is extremely important that the entire system be properly grounded.

The AC Input connector also supplies power to any additional loudspeakers connected to the loudspeaker’s gray Loop Output connector.

CAUTION: When looping AC power for loudspeakers, do not exceed the current capability of the AC Input connector (20 A) or the included AC power cable (15 A). Consider the total current draw for all loudspeakers on the circuit, including the first loudspeaker (Table 1).

AC Loop Output (Gray)

The gray AC Loop Output connector allows multiple UPQ-D Series loudspeakers to be looped and powered from a single power source. The 3-conductor powerCON 20 is rated at 20 A and uses a locking connector that prevents accidental disconnections. For applications that require multiple UPQ-D Series loudspeakers, connect the AC Loop Output of the first loudspeaker to the AC Input of the second loudspeaker and so forth.

The maximum number of loudspeakers that can be looped from the AC Loop Output connector is determined by the voltage of the power source, the current draw of the looped loudspeakers, the circuit breaker rating, and the rating of the AC power cable connected to the first UPQ-D Series loudspeaker (Table 1).

Table 1: Maximum UPQ-D1/2/3 that Can Be Looped with AC Power

Circuit Breaker/ Connector Rating	115 V AC	230 V AC	100 V AC
15 A	6 looped (7 total)	13 looped (14 total)	5 looped (6 total)
20 A	9 looped (10 total)	18 looped (19 total)	8 looped (9 total)

NOTE: Current draw for a UPQ-D Series loudspeaker is dynamic and fluctuates as operating levels change. The indicated number of loudspeakers that can be looped assumes that operating levels are normal and not such that loudspeakers are constantly limiting.

UPQ-D Series loudspeakers ship with a gray powerCON 20 cable mount connector, rated at 20 A, for assembling AC looping cables. Assembled 1-meter AC looping cables (PN 28.115.032.03) are also available from Meyer Sound.

WIRING AC POWER CABLES

UPQ-D Series loudspeakers ship with a gray powerCON 20 cable mount connector, rated at 20 A, for assembling AC looping cables (Figure 7). The pins on the powerCON 20 cable mount connector are labeled as follows:

- L (Line)
- N (Neutral)
- PE (Protective Earth or Ground)

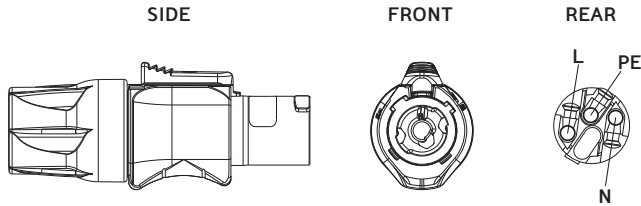

Figure 7: powerCON20 Cable Mount Connector

How AC power cables are wired is determined by the type of AC power distribution system used (see “AC Power Distribution” on page 13). When wiring AC power cables for single-line systems, use one of the wiring schemes shown in Figure 8 and described in Table 2:

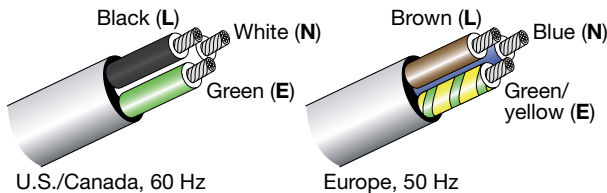

Figure 8: AC Wiring Scheme

Table 2: AC Wiring Scheme

Wire Color		Attach to the Following Terminal
U.S. / Canada 60 Hz	European 50 Hz	
Black	Brown	Hot or live (L)
White	Blue	Neutral (N)
Green	Green and Yellow	Protective earth / ground (E or PE)

CAUTION: When wiring AC power cables and distribution systems, it is important to preserve AC line polarity and connect the earth ground at both ends of the cable. A UPQ-D Series loudspeaker requires a grounded connection. Always use a grounded outlet and plug. It is extremely important that the system be properly grounded to operate safely and properly. Do not ground-lift the AC cable.

VOLTAGE REQUIREMENTS

A UPQ-D Series loudspeaker operates as intended when receiving AC voltage within the following range:

- 90–264 V AC, 50–60 Hz

If the voltage drops below 90 V, the loudspeaker uses stored power to continue operating temporarily; the loudspeaker powers off if the voltage does not return to its operating range.

If the voltage rises above 275 V, the power supply could become damaged.

CAUTION: The power source for a UPQ-D Series loudspeaker should always operate within the required operating range, at least a few volts from the upper and lower limits. This approach ensures that AC voltage variations from the service entry—or peak voltage drops due to cable runs—will not cause the loudspeaker’s amplifier to cycle on and off or cause damage to the power supply.

CURRENT REQUIREMENTS

Current draw for loudspeakers is dynamic and fluctuates as operating levels change. Because different cables and circuit breakers heat up at varying rates, it is important to understand the following types of current ratings and how they affect circuit breaker and cable specifications.

- **Idle Current** — The maximum rms current during idle periods.
- **Maximum Long-Term Continuous Current** — The maximum rms current during a period of at least 10 seconds. The maximum long-term continuous current is used to calculate temperature increases for cables and to ensure that the size and gauge of each cable conforms to electrical code standards. This current rating is also used to select appropriately rated, slow-reacting thermal breakers, which are recommended for loudspeaker power distribution. In addition, the maximum long-term continuous current can be used to calculate the AC looping capability for UPQ-D Series loudspeakers.
- **Burst Current** — The maximum rms current during a period of around 1 second. The burst current is used as a rating for magnetic breakers. It is also used for calculating the peak voltage drop in long AC cable runs according to the following formula:

$$V_{pk}(\text{drop}) = I_{pk} \times R(\text{cable total})$$
- **Maximum Instantaneous Peak Current** — A rating for fast-reacting magnetic breakers.

Use the information in Appendix C, “UPQ-D Series Specifications.” to select the appropriate cable gauge and circuit breaker ratings for the system’s operating voltage.

The minimum electrical service amperage required by a loudspeaker system is the sum of the maximum long-term continuous current for all loudspeakers. An additional 30 percent above the combined Maximum Long-Term Continuous amperages is recommended to prevent peak voltage drops at the service entry.

 **NOTE:** For best performance, the AC cable voltage drop should not exceed 10 V (10 percent at 115 V and 5 percent at 230 V). This approach ensures that the AC voltage variations from the service entry—or peak voltage drops due to longer cable runs—do not cause the amplifier to cycle on and off.

INTELLIGENT AC POWER SUPPLY

The UPQ-D Series Intelligent AC™ power supply automatically selects the correct operating voltage (allowing the loudspeaker to be used internationally without manually setting voltage switches), eliminates high inrush currents with soft-start power up, suppresses high-voltage transients up to several kilovolts, filters common mode and differential mode radio frequencies (EMI), and sustains operation temporarily during low-voltage periods.

Powering on UPQ-D Series

When powering on a UPQ-D Series loudspeaker, the following startup events take place over several seconds.

1. Audio output is muted.
2. Voltage is detected and the power supply mode is automatically adjusted as necessary.
3. The power supply ramps up.
4. On the user panel, the Active/Status LED flashes multiple colors successively.
5. The Active/Status LED turns solid green, indicating the loudspeaker is unmuted and ready to output audio.

 **CAUTION:** If the Active/Status LED does not turn solid green, or the UPQ-D Series loudspeaker does not output audio after 10 seconds, remove AC power immediately and verify that the voltage is within the required range. If the problem persists, contact Meyer Sound Technical Support.

ELECTRICAL SAFETY GUIDELINES

Make sure to observe the following important electrical and safety guidelines.

- The powerCON 20 connector should not be engaged or disengaged when under load or energized. Either de-energize or disconnect the other end of the cable.
- UPQ-D Series loudspeakers require grounded outlets. Always use a grounded outlet and plug.

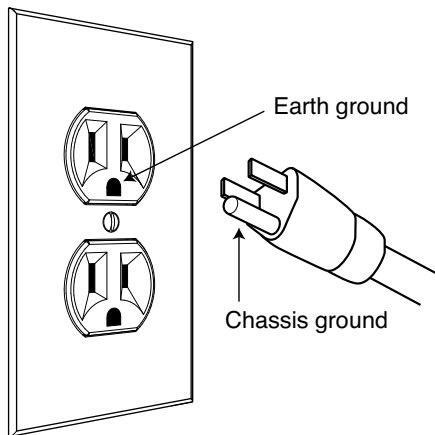

- Do not use a ground-lifting adapter or cut the AC cable ground pin.

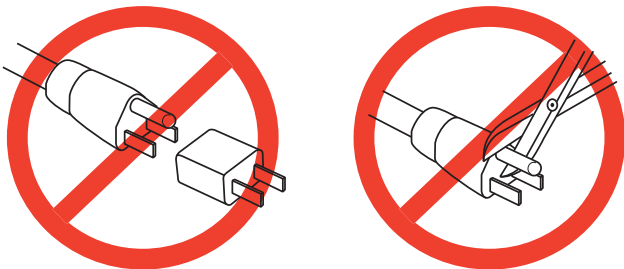

- Do not exceed the current capability of the 20 A AC Input connector for the loudspeaker. When looping loudspeakers, consider the total current draw for all loudspeakers on the circuit, including the first loudspeaker.
- Make sure the AC power cable for the loudspeaker has the appropriate power plug (on the other end) for the area in which the loudspeaker will be operated. In addition, the AC power cable must be rated for the total current draw of all loudspeakers looped from the power source.
- Do not operate the unit if the power cable is frayed or broken.
- Keep all liquids away from UPQ-D Series loudspeakers to avoid hazards from electrical shock.

CHAPTER 3: AMPLIFICATION AND AUDIO CONNECTORS

The UPQ-D Series drivers are powered by a proprietary 2-channel, open-loop, class D amplifier. The audio signal is processed with electronic crossover, correction filters for flat phase and frequency responses, and by driver protection circuitry. Each channel has peak and rms limiters that prevent driver over-excursion and regulate voice coil temperatures.

The UPQ-D Series user panel (Figure 9) includes Input and Loop output connectors for audio, Limit and Active LEDs, and RMS connectors and controls (see Chapter 6, “RMS Remote Monitoring System”).

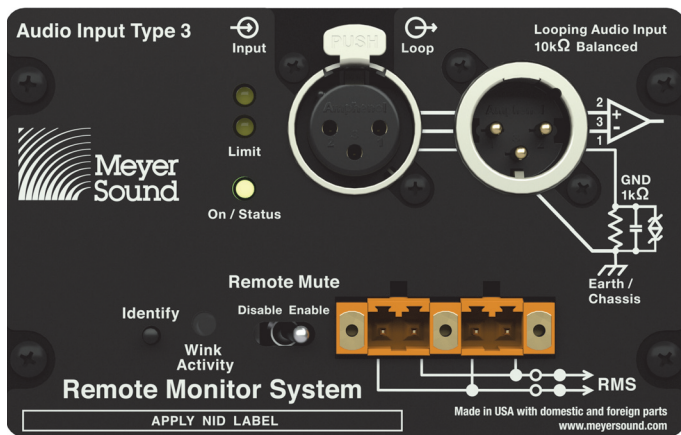

Figure 9: UPQ-D Series User Panel (3-pin XLR and optional RMS)

AUDIO CONNECTORS

The UPQ-D Series loudspeakers are available with XLR 3-pin (Figure 10) or 5-pin connectors (Figure 11) for audio Input and audio Loop output. XLR 5-pin connectors accommodate both balanced audio and RMS signals.

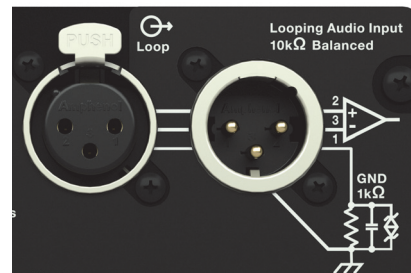

Figure 10: XLR 3-Pin Audio Connectors, Input and Loop Output

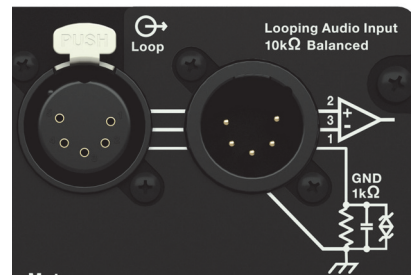



Figure 11: XLR 5-Pin Audio Connectors, Input and Loop Output

Audio Input (XLR 3-Pin or 5-Pin Female)

The XLR 3-pin or 5-pin female Input connector accepts balanced audio signals with an input impedance of 10 kΩ. The connector uses the following wiring scheme:

- **Pin 1** – 1 kΩ to chassis and earth ground (ESD clamped)
- **Pin 2** – Signal (+)
- **Pin 3** – Signal (-)
- **Pin 4** – RMS (polarity insensitive)
- **Pin 5** – RMS (polarity insensitive)
- **Case** – Earth (AC) ground and chassis

 **NOTE:** Pins 4 and 5 (RMS) are included only with XLR 5-pin connectors.

Pins 2 and 3 carry the input as a differential signal. Pin 1 is connected to earth through a 1 k Ω , 1000 pF, 15 V clamped network. This circuitry provides virtual ground lift for audio frequencies while allowing unwanted signals to bleed to ground. Make sure to use balanced XLR audio cables with pins 1–3 connected on both ends. Telescopic grounding is not recommended and shorting an input connector pin to the case may cause a ground loop, resulting in hum.

 **TIP:** If the loudspeaker produces unwanted noise or hiss, disconnect its input cable. If the noise stops, there is most likely nothing wrong with the loudspeaker. To locate the source of the noise, check the source audio, AC power, and electrical ground.

Audio Loop Output (XLR 3-Pin or 5-Pin Male)

The XLR 3-pin or 5-pin male Loop output connector allows multiple loudspeakers to be looped from a single audio source. The Loop output connector uses the same wiring scheme as the Input connector (see “Audio Input (XLR 3-Pin or 5-Pin Female)” on page 19). For applications that require multiple UPQ-D Series loudspeakers, connect the Loop output of the first loudspeaker to the Input of the second loudspeaker and so forth.

 **NOTE:** The Loop output connector is wired in parallel to the Input connector and transmits the unbuffered source signal even when the loudspeaker is powered off.

Calculating Load Impedance for Looped Audio Signals

To avoid distortion when looping multiple loudspeakers, make sure the source device can drive the total load impedance of the looped loudspeakers. In addition, the source device must be capable of delivering approximately 20 dBV (10 V rms into 600 Ω) to yield the maximum SPL over the operating bandwidth of the loudspeakers.

To calculate the load impedance for the looped loudspeakers, divide 10 k Ω (the input impedance for a single loudspeaker) by the number of looped loudspeakers. For example, the load impedance for 10 UPQ-D Series loudspeakers is 1000 Ω (10 k Ω / 10). To drive this number of looped loudspeakers, the source device should have an output impedance of 100 Ω or less. This same rule applies when looping a UPQ-D Series loudspeaker with other Meyer Sound self-powered loudspeakers.

 **NOTE:** Most source devices are capable of driving loads no less than 10 times their output impedance.

 **TIP:** Audio outputs from Meyer Sound’s Galileo GALAXY Network Platform have an output impedance of 50 ohms. Each output can drive up to 20 Meyer Sound (10 k Ω) loudspeakers without distortion.

 **CAUTION:** Make sure that all cables for looped loudspeakers are wired correctly (Pin 1 to Pin 1, Pin 2 to Pin 2, and so forth) to prevent the polarity from being reversed. If one or more loudspeakers in a system have reversed polarity, frequency response and coverage will be significantly degraded.

TRUPOWER LIMITING

The UPQ-D Series loudspeakers employ Meyer Sound’s advanced TruPower® limiting. Conventional limiters assume a constant driver impedance and set the limiting threshold by measuring voltage alone. This method is inaccurate, because driver impedances change as frequency content in the source material changes, and as thermal values for the loudspeaker’s voice coil and magnet vary. Consequently, conventional limiters often begin limiting prematurely, which reduces system headroom and dynamic range.

In contrast, TruPower limiting anticipates varying driver impedances by measuring both current and voltage to compute the actual power dissipation in the voice coil. This approach improves performance, both before and during limiting, by allowing the driver to produce the maximum SPL across its entire frequency range while also retaining signal peaks. TruPower limiting also eliminates power compression at high levels over lengthy periods, which helps regulate voice coil temperatures, thereby extending the life of the driver.

HF and LF Limit LEDs

The low- and high-frequency drivers for UPQ-D Series loudspeakers are powered by separate amplifier channels, each with their own limiter. Limiting activity is indicated with two Limit LEDs on the user panel. The top Limit LED (Figure 12) indicates limiting for the high-frequency channel and the bottom Limit LED indicates limiting for the low-frequency channel.

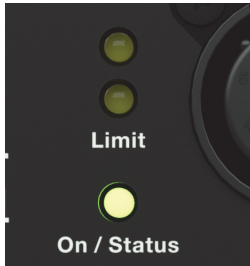



Figure 12: UPQ-D1/2/3 Limit LEDs

When engaged, the limiters not only protect the drivers but also prevent signal peaks from causing excessive distortion in the amplifier channels, thereby preserving headroom and maintaining smooth frequency response at high levels. When levels return to normal, below the limiter thresholds, limiting ceases.

A UPQ-D Series loudspeaker performs within its acoustical specifications at normal temperatures when the Limit LEDs are unlit, or when the LEDs are lit for 2 seconds or less and then turn off for at least 1 second. If the LEDs remain lit for longer than 3 seconds, the loudspeaker enters hard limiting where:

- Increases to the input level have no effect
- Distortion increases due to clipping
- Drivers are subjected to excessive heat and excursion, thereby compromising their lifespan

 **CAUTION:** The Limit LEDs indicate when a safe, optimum level is exceeded. If a UPQ-D Series loudspeaker system begins to limit before reaching the desired SPL, consider adding more units to the system.

CAUTION:

ON/STATUS LED

During normal operation, when a UPQ-D Series loudspeaker is powered on, the On/Status LED is solid green. If the loudspeaker encounters a hardware fault, or the unit begins to overheat, the LED flashes red. In some instances, the loudspeaker will continue to output audio while the LED flashes red, though with a reduction in the limiter threshold and acoustic output to protect the loudspeaker.

If a loudspeaker is overheating (for RMS-equipped loudspeakers, one can verify this situation in Compass RMS), a reduction in SPL may be necessary. If after a reduction in SPL and an appropriate cooling period the Active/Status LED continues to flash red (does not return to solid green), contact Meyer Sound Technical Support.

If the Active/Status LED flashes red and the loudspeaker does not output audio, contact Meyer Sound Technical Support immediately.

 **CAUTION:** If a UPQ-D Series loudspeaker system consistently overheats before reaching the desired SPL, consider adding more units to the system.

 **NOTE:** During startup, the On/Status LED flashes multiple colors successively. For more information about the power on sequence, see “Intelligent AC Power Supply” on page 16.

 **TIP:** When a UPQ-D Series loudspeaker is connected to an RMS network, the Compass RMS software provides additional feedback about the loudspeaker’s hardware status and operating temperature. For more information, see Chapter 6, “RMS Remote Monitoring System.”

AMPLIFIER COOLING SYSTEM

The UPQ-D Series loudspeaker is convection cooled. The amplifier’s heat sink provides natural convection cooling from the air flowing near its fins.

 **CAUTION:** To keep a UPQ-D Series loudspeaker from overheating, allow at least 3 inches behind the loudspeaker for proper ventilation.

 **TIP:** The UPQ-D Series loudspeaker heat sink can reach temperatures up to 80° C (176° F) during extreme operation. Wait 15 minutes for the unit to cool before touching.

CHAPTER 4: ADDING LOW FREQUENCY CONTROL

A UPQ-D Series loudspeaker system can be deployed with Meyer Sound self-powered low frequency control elements (see Table 3). These subwoofers achieve very low frequency responses and extend the system response appreciably, increasing the overall acoustic power of the system in the lowest frequencies.

The ideal ratio of UPQ-D Series loudspeakers to low frequency control element depends on the following variables:

- Subwoofer model
- System configuration
- Frequency content of the source material
- Headroom required for low frequencies

For most applications, the ratios in Table 3 should yield good results.

Table 3: Recommended Meyer Sound Subwoofer

Subwoofer	Frequency Response	Recommended Ratio (Number of UPQ-D Series per Subwoofer)
USW-210P	32–123 Hz ± 4 dB	1:1 for most applications 1:2 for applications requiring more low end
750-LFC	37–110 Hz ± 4 dB	1:1 for most applications
900-LFC	32–115 Hz ± 4 dB	2:1 for most applications 1:1 for applications requiring extreme low end
1100-LFC	30–85 Hz ± 4 dB	4:1 for most applications

ADDING SUBWOOFERS BY DAISY-CHAINING

Full-range signals can be connected directly to Meyer Sound self-powered loudspeakers, because the loudspeakers have built-in active crossovers. Subwoofers can be added to a UPQ-D Series system by simply daisy-chaining them to the UPQ-D Series loudspeakers.

To daisy-chain the suggested number of UPQ-D Series loudspeakers for the selected subwoofer (see Table 1):

1. Connect the source signal to the Input of the first UPQ-D Series loudspeaker, then connect the Loop output of the first loudspeaker to the Input of the second loudspeaker and so forth.
2. Connect the Loop output of the last UPQ-D Series loudspeaker in the chain to the subwoofer Input.

When UPQ-D Series loudspeakers are coplanar, or they are very close together (about four to six feet like in the case of pole mounting), the phase response will work well in the area of interaction and the result will be a fairly flat frequency response. However, the response will show an increase in the 60–200 Hz range where the response of the loudspeakers overlaps.



NOTE: If the subwoofer’s Limit LEDs begin to light before reaching the required SPL, consider adding more subwoofers to meet the SPL requirements without exposing the drivers to excessive heat and excursion.

USING A PROCESSOR

In larger systems when individual control for the UPQ-D Series loudspeakers and subwoofers are needed or desired, if the UPQ-D Series loudspeakers and subwoofer are more than six feet apart, or if a delay is required between them, use a measurement system like Meyer Sound’s SIM to determine appropriate delay and polarity settings.



CAUTION: Make sure the source signal is sufficient to drive the total load impedance of the daisy-chained loudspeakers (see “Calculating Load Impedance for Looped Audio Signals” on page 20).



TIP: MAPP can be used to accurately predict the appropriate loudspeaker deployment and subwoofer integration for loudspeaker systems, complete with coverage data, system delay and equalization settings, rigging information, and detailed design illustrations. For more information, see “MAPP System Design Tool” on page 33.

CHAPTER 5: QUICKFLY RIGGING

The UPQ-D Series loudspeakers are compatible with Meyer Sound's QuickFly® system, a comprehensive collection of custom-designed rigging, flying, and mounting options. Comprising rugged, reliable, and easy-to-configure components, QuickFly supports deployment of UPQ-D Series loudspeakers as either individual loudspeakers or as arrays at precise angles to take full advantage of their directional components. The top and bottom plates for the UPQ-D Series cabinet are constructed of heavy-duty, high-strength, corrosion-resistant 6061-T6 aluminum and include threaded metric holes (for M10 screws) for easy connection to QuickFly rigging and third-party mounting options.

IMPORTANT SAFETY CONSIDERATIONS!

When installing Meyer Sound loudspeakers, the following precautions should always be observed:

- All Meyer Sound products must be used in accordance with local, state, federal, and industry regulations. It is the owner's and user's responsibility to evaluate the reliability of any rigging method for their application. Rigging should only be carried out by experienced professionals.
- Use mounting and rigging hardware that has been rated to meet or exceed the weight being hung.
- Make sure to attach mounting hardware to the building's structural components (studs or joists), and not just to the wall surface. Verify that the building's structure and the anchors used for the installation will safely support the total weight of the mounted loudspeakers.
- Use mounting hardware appropriate for the surface where the loudspeaker will be installed.
- Make sure bolts and eye bolts are tightened securely. Meyer Sound recommends using Loctite® on eye bolt threads and safety cables.
- Inspect mounting and rigging hardware regularly. Immediately replace any worn or damaged components.

BASIC EYE BOLT RIGGING

The UPQ-D Series loudspeaker ships with two M10 threaded, 25 mm eye bolts that attach to the top or bottom of the loudspeakers and can be used to suspend them. A minimum of two eye bolts is required when suspending a single loudspeaker. The use of two eye bolts provides the added flexibility of aiming and tilting the loudspeaker for targeted coverage.

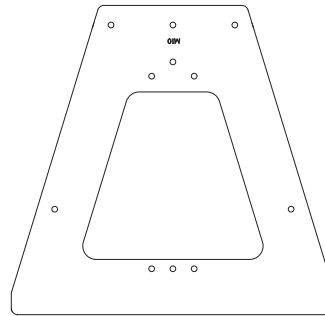

Figure 13: UPQ-D Series Top Plate with Threaded Holes for Eye Bolts

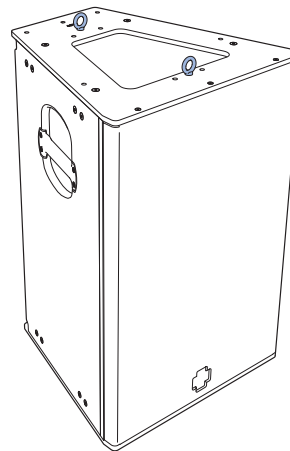

Figure 14: UPQ-D Series Loudspeaker with Two Eye Bolts



NOTE: Up to two UPQ-D Series loudspeakers, oriented vertically, can be suspended with Meyer Sound eye bolts at a 5:1 safety factor. For this configuration, the top loudspeaker would have two eye bolts installed on its top plate and two eye bolts installed on its bottom plate for connecting to the second loudspeaker. Additional M10 eye bolts (PN 40.185.013.01 for a set of 2) are available from Meyer Sound.

UPQ-D SERIES RIGGING ACCESSORIES

To move beyond the basic eye bolt rigging, Meyer Sound offers UPQ-D Series rigging accessories that facilitate more configurations (Table 4).

Table 4: ULTRA-X40/42 Rigging Options

Model	Features
MYA-UPQ Mounting Yoke (PN 40.185.052.01)	The MYA-X40 Yoke suspends a single UPQ-D Series loudspeaker and supports a wide range of horizontal and vertical adjustments. The bottom bar of the yoke attaches to the bottom of the loudspeaker. The kit includes two M10 x 20mm knobs/washers and two M10 x 1.5 x 70 hex head screws.
MPA-UPQ Array Adapter Plate (PN 40.185.054.01)	The MPA-UPQ Array Adapter Plate kit includes two plates to facilitate installation of UPQ-D Series loudspeakers in both horizontal and vertical clusters at angles between 34° and 50°. The kit includes eight M10 x 20 mm knobs and washers.
Eye bolts (PN 40.185.013.01)	Replacement black-coated M10 1.5 x 17 mm eye bolts, quantity 2

POLE-MOUNTING THE UPQ-D SERIES

A single UPQ-D Series loudspeaker may be mounted on a heavy-duty loudspeaker stand with a standard 38 mm (1.5 in) pole using its integral pole mount receptacle. The load rating for the stand must meet or exceed the weight of the UPQ-D Series loudspeaker (95 lb or 43 kg) and the pole must be installed according to the manufacturer’s instructions.

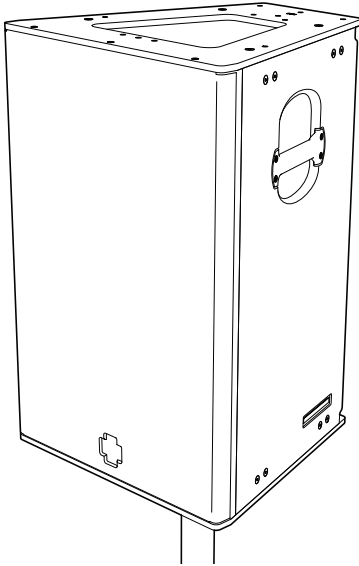

Figure 15: UPQ-D Series Mounted on Pole

CAUTION: Make sure the pole is designed to support the total weight of the UPQ-D Series loudspeaker and observe all safety precautions specified by the pole manufacturer.

THE MYA-UPQ MOUNTING YOKE

The MYA-UPQ (PN 40.185.052.01) mounting yoke suspends a single UPQ-D Series loudspeaker and allows a wide range of horizontal and vertical adjustment. The mounting yoke’s bottom bar attaches to the bottom plate of the loudspeaker with two M10 mounting screws (included). A “C” or “G” hanging clamp and steel safety cable (not included) are required to suspend the MYA-UPQ mounting yoke.

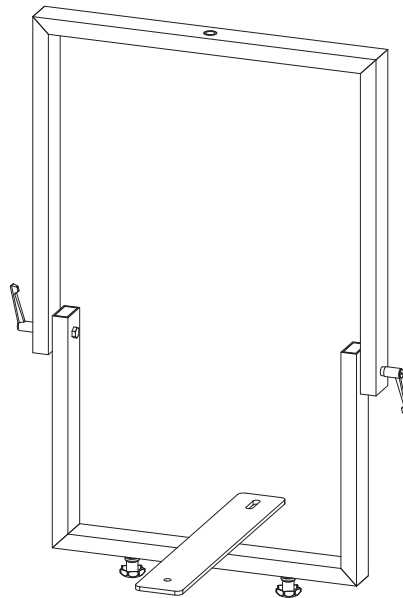

Figure 16: MYA-UPQ Mounting Yoke

NOTE: The top bar of MYA-UPQ mounting yoke accommodates hanging clamps with standard 1/2-inch or 12 mm bolts.

THE MPA-UPQ ARRAY ADAPTER

The MPA-UPQ array adapter provides a solid connection between UPQ-D Series loudspeakers to form horizontal and vertical arrays of up to three loudspeakers. The six M10 screw holes at the front of the adapter plate are used to adjust the distance between the loudspeakers to achieve the desired splay angle (from 34° to 50°) and coverage. The adapter plate has three rows of shackle holes that offer the flexibility of flying horizontal and vertical arrays, as well as single loudspeakers.

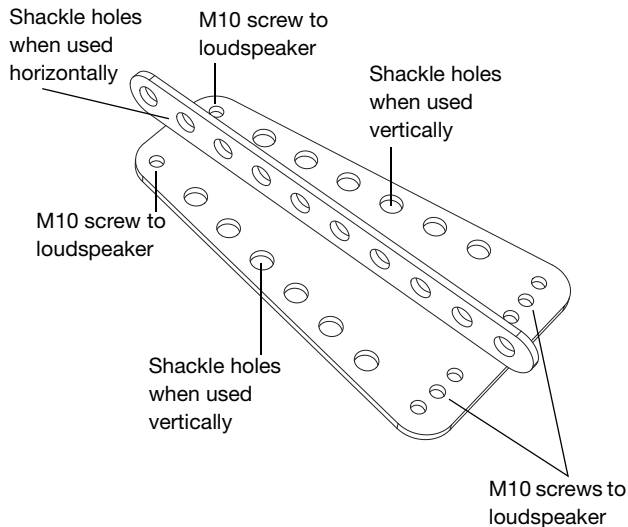

Figure 17: MPA-UPQ Array Adapter Plate

The MPA-UPQ array adapter kit (PN 40.185.054.01) includes two plates and eight M10 knobs and washers. A single kit can create an array of two UPQ-D Series loudspeakers; two kits are required for an array of three loudspeakers.

Arrays are assembled by attaching the array adapter plates to the top and bottom plates of the UPQ-D Series loudspeakers and securing them with the included M10 knobs and washers.



CAUTION: The MPA-UPQ array adapter supports a maximum of three UPQ-D Series loudspeakers in an array.

Suspending Single Loudspeakers Vertically with the MPA-UPQ

A single MPA-UPQ array adapter plate can be used to suspend a single UPQ-D Series loudspeaker vertically. The adapter plate attaches to the top center of the loudspeaker with the included M10 knobs. Shackles attach to the adapter plate's middle shackle holes (oriented up).

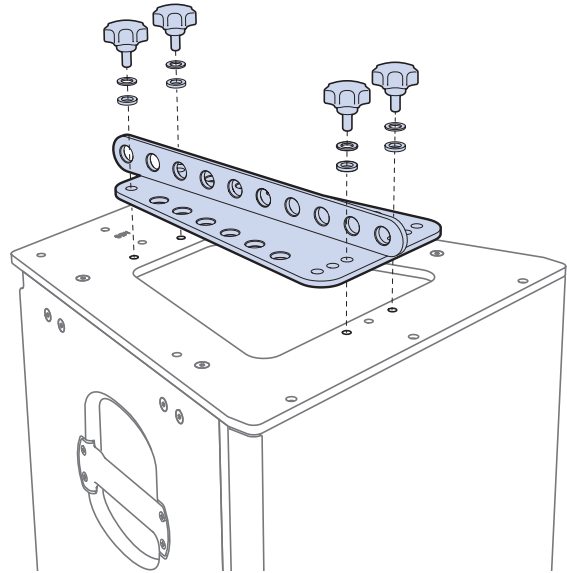

Figure 18: Attaching an Array Adapter Plate



TIP: A second MPA-UPQ array adapter plate attached to the bottom can be used to pull back for severe downtilt angles using the last shackle hole.

Suspending Single Loudspeakers Horizontally with the MPA-UPQ

Two MPA-UPQ array adapter plates can be used to suspend a single UPQ-D Series loudspeaker horizontally. The adapter plates attach to the top and bottom edges of the loudspeaker with the included M10 knobs. Shackles attach to the adapter plate's side shackle holes (oriented up).

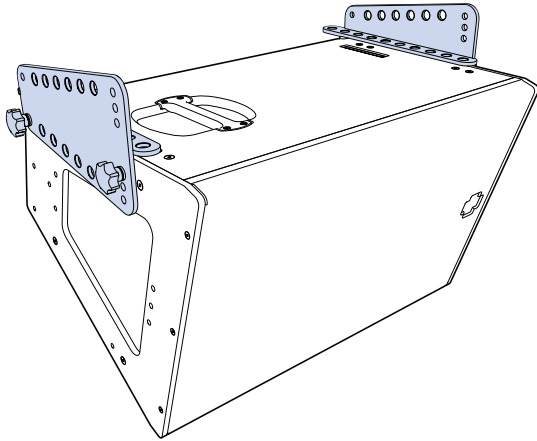

Figure 19: MPA-UPQ Suspending a Single Loudspeaker Horizontally

Horizontal Arrays with the MPA-UPQ

MPA-UPQ horizontal arrays are constructed by placing adapter plates on the tops and bottoms of the loudspeakers between each loudspeaker. The adapter plates are oriented with the middle shackle row up.

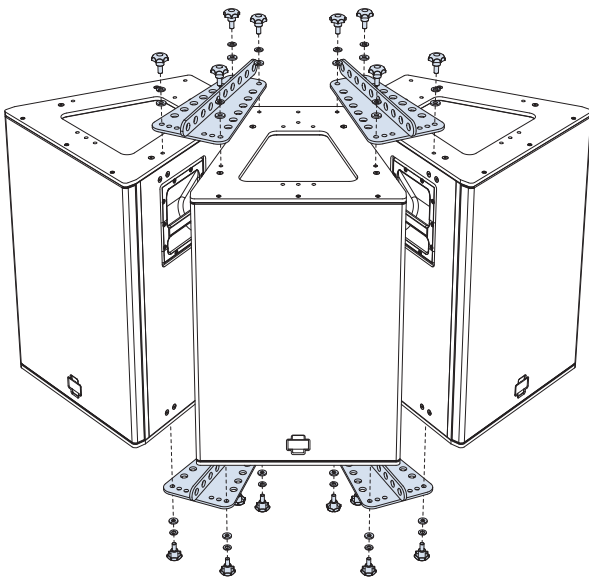

Figure 20: MPA-UPQ, Horizontal Array

Vertical Arrays with the MPA-UPQ

MPA-UPQ vertical arrays are constructed by placing adapter plates on the tops and bottoms of the loudspeakers between each loudspeaker. The adapter plates are oriented with the middle shackle row in.

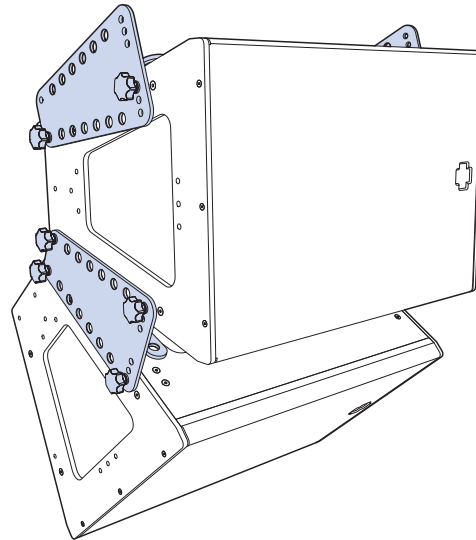

Figure 21: MPA-UPQ, Vertical Array

NOTE: For a list of available splay angles for arrayed UPQ-D Series loudspeakers, see “MPA-UPQ Splay Angles for Arrayed Loudspeakers” on page 29.

NOTE: Optimal acoustical performance for a UPQ-D Series array is achieved by using the adequate number of units as well as selecting the specific angles between cabinets to fill the requirements of the application. In general, larger angles can create a hole in the coverage and smaller angles can create too much interaction.

NOTE: MAPP, covered in greater detail in Chapter 6, is the tool of choice to enable users to make accurate and comprehensive predictions for optimal coverage(s) during the design phase.

MPA-UPQ Splay Angles for Arrayed Loudspeakers

The MPA-UPQ array adapter plate has six different M10 screw holes for adjusting the splay angle for arrayed UPQ-D Series loudspeakers. The following illustrations show the possible splay angles for arrayed loudspeakers.

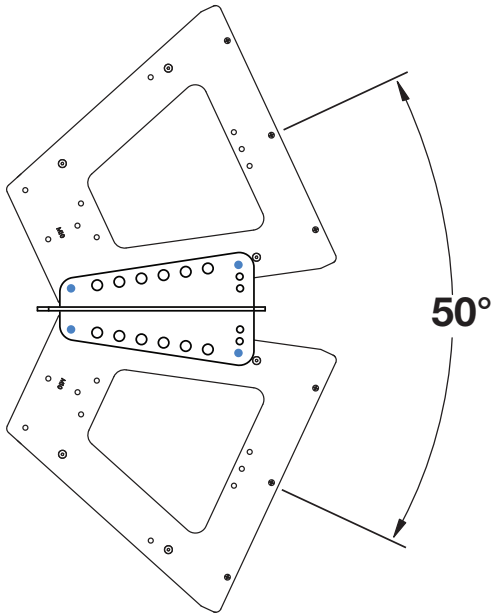

Figure 22: MPA-UPQ with Loudspeakers Arrayed at 50°

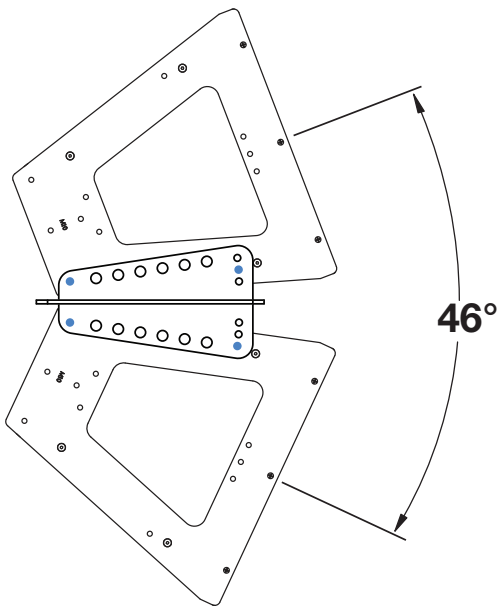

Figure 23: MPA-UPQ with Loudspeakers Arrayed at 46°

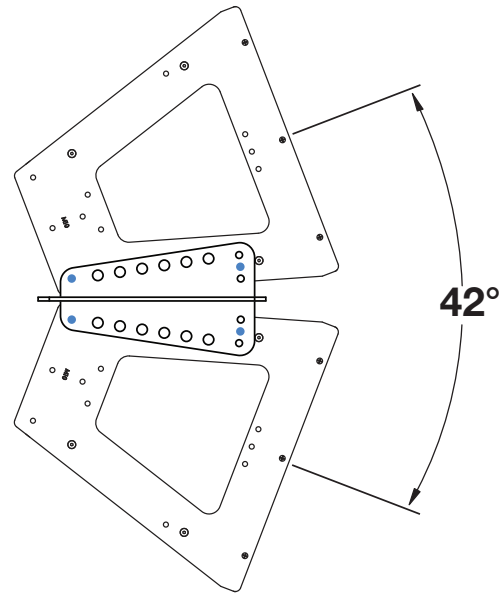

Figure 24: MPA-UPQ with Loudspeakers Arrayed at 42°

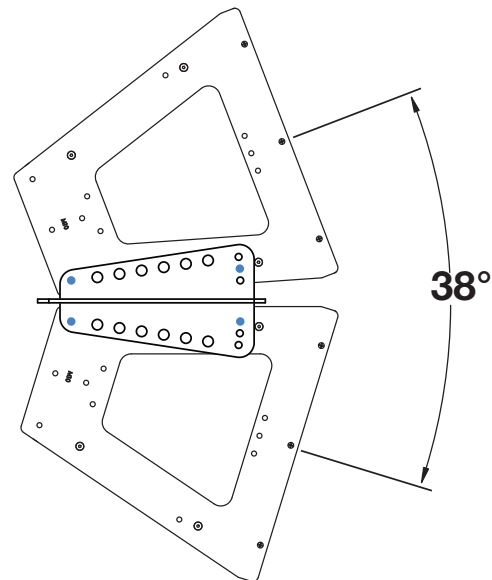

Figure 25: MPA-UPQ with Loudspeakers Arrayed at 38°

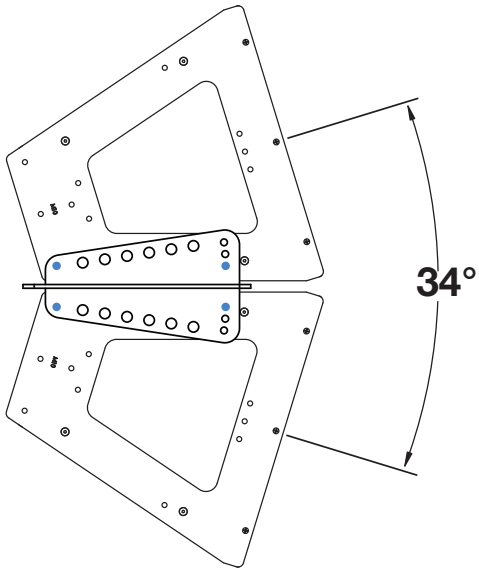



Figure 26: MPA-UPQ with Loudspeakers Arrayed at 34°

CHAPTER 6: RMS REMOTE MONITORING SYSTEM

The UPQ-D Series loudspeakers optionally include an RMS remote monitoring system module, allowing them to be connected to an RMS network. RMS reports, in real time, the status and power usage of multiple Meyer Sound loudspeakers from a Mac® or Windows®-based computer. The RMsServer™ communicates with Meyer Sound loudspeakers equipped with RMS modules. RMsServer is a compact, Ethernet-based hardware unit with two FT-10 RMS data ports. RMsServer stores system configurations internally, eliminating most manual data entry. Systems can be monitored from a computer at front-of-house or backstage, or from a laptop anywhere within the venue over WiFi.

 **NOTE:** For the latest RMS system requirements, visit the Meyer Sound website (<http://www.meyersound.com>).

 **NOTE:** RMS does not control AC power.

COMPASS CONTROL SOFTWARE

Compass Control Software provides extensive system status and performance data for each loudspeaker via the RMsServer tab including amplifier voltage, limiting activity, power output and driver status, as well as mute and solo capability. Loudspeakers are added to the RMS network and assigned a node name during a one-time discovery procedure. After loudspeakers are identified on the RMS network, they appear in Compass RMS as icons that can be customized to suit the needs of the application (Figure 27).

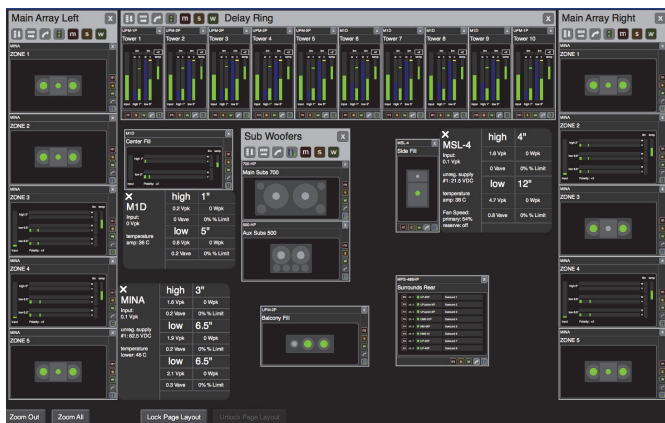

Figure 27: Compass RMS Window

Individual loudspeakers can be physically identified with the Wink option in RMS which lights the Wink LED on the RMS module of that particular loudspeaker. Conversely, a loudspeaker can be identified in Compass by pressing the Identify button on the loudspeaker's RMS module.

Loudspeaker icons can be arranged in Compass RMS and saved as pages to represent how the loudspeakers have been deployed in the system. Multiple pages can be saved and recalled for specific performances and venues.

RMS MODULE

The UPQ-D Series RMS user panel (Figure 28) includes an Identify button, Remote Mute switch, Wink/Activity LED, and two Network connectors.

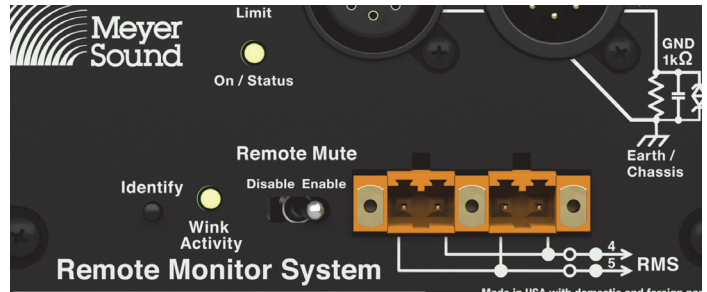



Figure 28: UPQ-D Series RMS Module

 **NOTE:** The Identify button and Wink/Activity LED on the RMS user panel are used exclusively by RMS and have no effect on the acoustical or electrical activity of the loudspeaker.

Identify Button

The Identify button serves the following functions:

- If the loudspeaker has not yet been discovered on the RMS network (Wink/Activity LED not lit), press the Identify button to discover it.
- To remove the loudspeaker from the RMS network, press and hold the Identify button during startup (see “Resetting the RMS Module” on page 32).
- To *wink* a discovered loudspeaker, press the Identify button. The Wink LED on the loudspeaker icon in Compass RMS lights up and the Wink/Activity LED on the loudspeaker's RMS user panel turns solid green. Press the Identify button again to unwink the loudspeaker.



TIP: The loudspeaker can also be winked by clicking the Wink button on the loudspeaker icon in Compass RMS.

Wink/Activity LED (Green)

The green Wink/Activity LED indicates the status of the loudspeaker:

- During startup, the LED flashes green 10 times.
- If the loudspeaker has not yet been discovered on the RMS network, the LED is not lit after startup.
- If the loudspeaker has been successfully discovered on the RMS network, the LED flashes green continuously and flashes more rapidly with increased data activity.
- When the loudspeaker is winked, either by clicking the Wink button in Compass RMS or by pressing the Identify button on the RMS user panel, the LED is solid green. The LED remains solid green until the loudspeaker is unwinked.



TIP: The Wink function is useful for identifying the physical loudspeaker corresponding to a loudspeaker icon in Compass RMS.

Remote Mute Switch

The recessed Remote Mute switch on the UPQ-D Series RMS module (Figure 29) determines whether Compass RMS can control muting and soloing of the loudspeaker. The UPQ-D Series ships from the factory with the switch enabled.

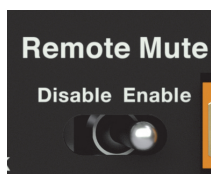

Figure 29: Remote Mute Switch

- **Disable:** When the Remote Mute switch is set to Disable (to the left), the loudspeaker cannot be muted or soloed from Compass RMS.
- **Enable:** When the Remote Mute switch is set to Enable (to the right), the loudspeaker can be muted and soloed from Compass RMS.



NOTE: Compass RMS has a preference that can be set to disable Mute and Solo functions, eliminating any possibility of accidentally muting loudspeakers.

RMS Network Connectors

The Weidmuller 2-conductor, locking connectors transfer data to and from the RMS network. Two connectors are provided to allow for easy connection of multiple (daisy-chained) loudspeakers on the network. Included with each RMS-equipped loudspeaker are RMS cable connectors and mounting blocks for constructing RMS cables. The mounting blocks allow the Weidmuller connectors to be securely attached to the RMS module with screws.

NEURON ID FOR RMS MODULE

Each RMS module has a unique 12-character Neuron ID (NID) that identifies the loudspeaker on the network. The NID is automatically detected by RMServer but can also be entered manually, if necessary, when configuring RMS systems in Compass RMS without loudspeakers present. The NID label is located on the RMS user panel near the orange Network connectors.

RESETTING THE RMS MODULE

The Identify button can be used to reset the UPQ-D Series RMS module when powering on the loudspeaker. This action will cause the module to be removed from the RMS network.

To reset the RMS module:

1. Power down the loudspeaker.
2. Press and hold the Identify button.
3. While continuing to hold down the Identify button, power on the loudspeaker.
4. After the Wink/Status LED flashes on and off, release the Identify button. The RMS module is reset and the loudspeaker is removed from the RMS network.

CHAPTER 7: SYSTEM DESIGN AND INTEGRATION TOOLS

This chapter introduces MAPP, Meyer Sound's patented system design tool, the Galileo GALAXY Network Platform, and SIM, a comprehensive system for measurement and analysis.

MAPP SYSTEM DESIGN TOOL

The MAPP System Design Tool (Figure 30) is a powerful, cross-platform application for accurately predicting the coverage pattern, frequency response, phase response, impulse response, and SPL capability of single or arrayed Meyer Sound loudspeakers.

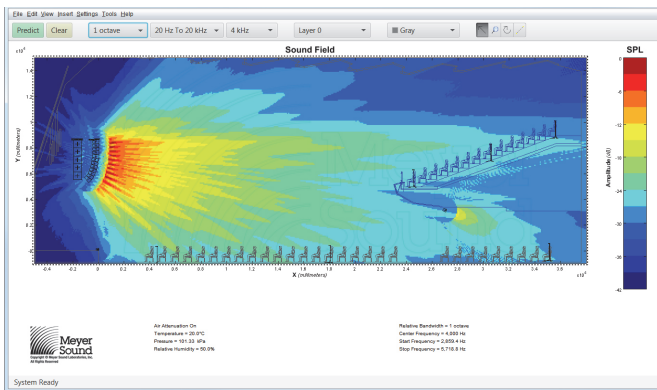

Figure 30: MAPP System Design Tool

Whether planning for fixed installations or for tours with multiple venues, use MAPP to accurately predict the appropriate loudspeaker deployment for each job, complete with coverage data, system delay and equalization settings, rigging information, and detailed design illustrations. MAPP's accurate, high-resolution predictions ensure that systems will perform as expected, thereby eliminating unexpected coverage problems and minimizing onsite adjustments.

The key to the accuracy of MAPP's predictions is Meyer Sound's exhaustive database of loudspeaker measurements. Performance predictions for each loudspeaker are based on 720 1/48th-octave-band measurements taken with a SIM audio analyzer (see "SIM Measurement System" on page 34) in the Meyer Sound anechoic chamber. The extraordinary consistency between Meyer Sound loudspeakers guarantees that predictions from MAPP will closely match their actual performance.

MAPP client software allows for configuration of Meyer Sound loudspeaker systems and definition of the environment in which they operate, including air temperature, pressure, humidity, and even the location and composition of surfaces. Importation of CAD (.DXF) files containing detailed venue information to act as a visual aid is also possible.

MAPP prediction requests are sent by the client software to Meyer Sound servers, where complex, high-resolution (magnitude and phase) polar data is processed with sophisticated acoustical prediction algorithms. The resulting predictions are then displayed in the MAPP client software.



TIP: Meyer Sound offers seminars and webinars on using MAPP. For more information, visit

www.meyersound.com.

MAPP Capabilities

With MAPP, a user can:

- Simulate different loudspeaker configurations to refine system designs and determine the best coverage for intended audience areas
- Model loudspeaker interactions to locate constructive and destructive interferences, so that loudspeakers can be re-aimed and repositioned as necessary
- Place microphones anywhere in the sound field and predict loudspeaker frequency response, phase response, and sound pressure levels at each microphone position
- Determine delay settings for fill loudspeakers using the Inverse Fast Fourier Transform feature
- Preview the results of signal processing to determine optimum settings for the best system response
- Automatically calculate load information for arrays to determine necessary minimum rigging capacity, front-to-back weight distribution, and center of gravity location
- Generate and export system images and full-system PDF reports for client presentations

GALILEO GALAXY NETWORK PLATFORM

The Galileo GALAXY Network Platform is a sophisticated loudspeaker management tool for controlling all Meyer Sound speaker types. The GALAXY loudspeaker processor extends a high level of audio control in driving and aligning loudspeaker systems with multiple zones. It provides a powerful tool set for corrective equalization (EQ) and creative fine-tuning for a full range of applications from touring to cinema.

Users can readily program the GALAXY processor using Compass software running on a host computer or via the Compass Go application for the iPad. Compass Control Software includes custom-designed settings for each family of speakers, as well as to integrate families together. For example, the Product Integration feature matches the phase characteristics between Meyer speaker families to ensure the most coherent summation.

Processing tools for inputs and outputs include delay, parametric EQ and U-Shaping EQ. Output processing also includes polarity reversal, Low-Mid Beam control (LMBC), atmospheric correction, and All Pass filters.

The built-in summing and delay matrices allow a user to easily assign gain and delay values, respectively, at each cross point. This capability greatly facilitates using one loudspeaker to satisfy multiple purposes.

Front panel controls let a user intuitively and quickly operate a GALAXY processor without a computer during live use.

The rear panel includes SIM bus port(s) for direct connection to Meyer Sound's SIM audio analyzer, allowing the GALAXY processor to function as a line switcher for the analyzer. With this capability, a user can take measurements from any selection of GALAXY inputs and outputs without patching beyond a single connection to the analyzer.

The GALAXY 408, GALAXY 816 and GALAXY 816-AES3 processor versions have the same audio processing capability with different I/O. See www.meyersound.com to locate their datasheets for more information.

SIM MEASUREMENT SYSTEM

The SIM audio analyzer is a high-resolution audio measurement system comprising software, hardware, microphones, and accessory cables. SIM presents measured audio frequencies at a resolution of 48 points per octave, where the 48 points per octave are arranged in even frequency increments in each octave group, equal to the total frequencies in that octave divided by 48. This resolution

allows application of precise corrections to balance system response using frequency and phase domain information.

Source Independent Measurement Technique

The SIM audio analyzer implements Meyer Sound's source independent measurement technique. This dual-channel method makes analysis of statistically unpredictable excitation signals possible. Any excitation signal, within the desired frequency range, can be used to obtain highly accurate measurements for acoustical or electronic systems.

For example, during a performance, both the input signal and the measured output of the loudspeaker system can be analyzed by SIM and the results can be used to:

- View measurement data as amplitude versus time (impulse response) or amplitude and phase versus frequency (frequency response)
- View single-channel frequency domain data with a logarithmic frequency axis
- Determine and internally compensate for propagation delays using the SIM Delay Finder

SIM Applications

SIM's main applications are testing and aligning loudspeaker systems, which entails:

- Measuring propagation delays between subsystems to determine appropriate delay times
- Verifying correct polarity
- Measuring and comparing phase responses of subsystems
- Measuring variations in frequency response caused by the acoustical environment and the placement and interaction of loudspeakers to determine corrective equalization
- Optimizing subwoofer integrations
- Optimizing loudspeaker arrays

SIM can also be used in the following applications:

- Microphone calibration and equalization
- Transducer evaluation and correction
- Echo detection and analysis
- Vibration analysis
- Architectural acoustics

APPENDIX A: MEYER SOUND WEATHER PROTECTION

The Weather Protection option from Meyer Sound is intended to increase the useful life of Meyer Sound loudspeakers when they are installed outdoors and exposed to different and often harsh weather conditions.

Meyer Sound Weather Protection includes a penetrating treatment to raw wood, use of special primers, and plating on all steel parts used (or alternatively, the use of stainless steel hardware). Weather Protection is designed to prevent malfunctions caused by harsh operating environments and slows the accelerated wear and tear that occurs in outdoor environments.

When Is Weather Protection Advisable?

Weather Protection is strongly recommended for all permanent outdoor installations where loudspeakers are directly exposed to the elements. This recommendation includes desert and semi-arid climates, where protection against dust and sand is important, and where infrequent rainstorms can contribute to deterioration of loudspeaker components.

Weather Protection is also recommended when the loudspeakers are sheltered from direct exposure to precipitation, but are nevertheless exposed to prolonged high humidity, fog or mist. Examples would be installations on covered outdoor terraces or pavilions.

Weather Protection is further advisable for portable or touring systems when any significant outdoor use is anticipated. Even though standard procedures may call for using external protective measures, these are often not implemented in time to prevent moisture intrusions that could lead to premature performance degradation of the loudspeaker.

Climate Variation and Owner Maintenance

The wear and tear on a loudspeaker will vary significantly with different climatic conditions. For example, a weather-protected loudspeaker installed in a sunlight-exposed location on an ocean pier will experience much harsher conditions than a loudspeaker in a similar installation that is shaded by trees and exposed only to rainfall. The constant exposure to direct UV radiation and a salt air environment will cause a loudspeaker to wear more quickly than one with partial UV shielding and exposed only to freshwater moisture.

Wear can eventually affect the performance of the loudspeaker. It also affects aesthetics. For example, in salt

air environments, the exterior grille can quickly show signs of oxidation, causing unsightly discoloration.

Apart from selecting suitable weather protection, the progress of wear and tear on the loudspeaker can be slowed by a regular schedule of inspection and cleaning. This maintenance is particularly necessary in harsh environments. Inspection and cleaning should include routine removal of any visible oxidation or environmental particulates, as these can accelerate metal corrosion or decay of the cabinet. If installed loudspeakers are not in use for an extended period, exterior protection or temporary removal and storage of the loudspeakers should be considered.

Benefits of Weather Protection

There are several benefits to selecting the Meyer Sound Weather Protection option:

Functionality—Weather Protection prolongs the service life of the loudspeaker by preventing premature degradation of internal components.

Safety—Weather Protection lessens the chance of electrical malfunctions or structural failures.



WARNING: IT IS THE RESPONSIBILITY OF PURCHASERS/USERS/OPERATORS TO SELECT WEATHER PROTECTION WHEN APPROPRIATE FOR THEIR USE AND TO PERIODICALLY INSPECT THEIR LOUDSPEAKER INSTALLATIONS FOR ANY DETERIORATION THAT MAY LEAD TO SAFETY CONCERNS.

Aesthetics—Weather Protection slows wear and tear on the exterior of the loudspeaker in harsh conditions. Early signs of wear and tear on the exterior of the loudspeaker indicate over-exposure to the elements.

Standards Compliance—Weather Protection helps in meeting IP ratings for loudspeakers. IP ratings are an internationally recognized standard often used in installations involving our products. A further explanation of IP ratings is given in the “IP Ratings” Section on page 37.

WEATHER PROTECTION COMPONENTS

Standard Weather Protection

Meyer Sound designs toward an IP rating of IPX4 (see “IP Ratings” on page 37) for Standard Weather Protection, which includes the following components:

- Wood treatment—Prior to cabinet manufacturing, the raw wood receives a special treatment that penetrates and stabilizes the wood fibers to withstand a wide range of temperatures and exposure to extreme humidity.
- Cabinet finishing—The assembled cabinets receive a highly impervious finish that includes a sealing primer and a finishing topcoat. The coatings are applied on both surfaces, with one coat on the interior and two on the exterior. The final step is a two-part modified acrylic urethane similar to that used in military applications.
- Driver treatment—All cone drivers are coated with a water-resistant sealant.
- Exterior protection—Grille frames are coated to resist corrosion, and all components that mount to the cabinet use custom gaskets and stainless steel fasteners.
- Removable rain hood—The rain hood is designed to shield connectors even in wind-driven rain.

If in doubt about an installation method, contact Meyer Sound Technical Support for assistance.

Always discuss the environmental conditions of your Meyer Sound installation with your Sales Manager, and verify the availability of Weather Protection for your selected loudspeaker models. The Sales Manager, together with Technical Support, will verify the appropriate level of weather protection for the loudspeakers and related rigging hardware.

INSTALLATION PRACTICES

Meyer Sound assumes normal and accepted installation practices are used when installing Meyer Sound Loudspeakers outdoors. Deviation from such practices may cause weather protection to be ineffective and void the warranty for the loudspeaker.

Examples of unacceptable and acceptable installation practices include:

- Loudspeakers installed outdoors should not face upward.
- Loudspeakers with a rain hood should be installed in such a way that the rain hood opening is not facing any direction but down.
- Meyer Sound-supplied rigging components should not be modified (for example, by drilling additional holes in a MUB for mounting to a wall). When an installer/integrator modifies a Meyer Sound supplied rigging component to support their installation method, it is considered compromised and out of warranty.
- All loudspeaker cabling must be installed with a “drip-loop” or equivalent method to ensure that rain or water is NOT wicked toward the loudspeaker.

IP RATINGS

IP stands for “Ingress Protection.” The current format for expressing an IP rating is a 2-digit code. The first digit of an IP rating represents protection from solid objects. The second digit of an IP rating represents protection from water or moisture. Table 5 provides a chart of IP ratings and the corresponding definitions of the rating.



NOTE: IP ratings only apply to the “ENCLOSURE.” A loudspeaker is considered an enclosure and as such an IP rating can be applied to it. Rigging hardware is not an enclosure and therefore IP ratings do not apply. Also, cable and cable-mount connectors used to connect to the loudspeaker are NOT part of the enclosure and therefore not part of the IP rating. Only the chassis-mounted part of the connector is considered part of the enclosure.

Table 5: IP Ratings Definition Chart

First Digit (Protection against solid objects)	Definition	Second Digit (Protection against liquids)	Definition
X	Characteristic numeral is not required to be specified.	X	Characteristic numeral is not required to be specified.
0	No protection.	0	No protection.
1	Protected against solid objects over 50 mm.	1	Protected against vertically falling drops of water.
2	Protected against solid objects over 12 mm.	2	Protected against direct sprays up to 15° from the vertical.
3	Protected against solid objects over 2.5 mm.	3	Protected against direct sprays up to 60° from the vertical.
4	Protected against solid objects over 1 mm.	4	Protected against direct sprays from all directions. Limited ingress permitted.
5	Protected against dust. Limited ingress permitted.	5	Protected against low-pressure jets of water from all directions. Limited ingress permitted.
6	Totally protected against dust.	6	Protected against strong jets of water from all directions. Limited ingress permitted.
		7	Protected against the effect of temporary immersion between 15 cm and 1 m.
		8	Protected against the effect of long-term submersion of 1 m or more.

APPENDIX B: RAIN HOODS

Weather-protected UPQ-D Series loudspeakers include a rain hood for indoor/outdoor touring and sheltered outdoor installations. Meyer Sound offers two rain hood models: A fixed rigid rain hood for permanent installations and a foldable hood for portable applications. Please specify the desired rain hood when placing an order.

RIGID RAIN HOOD

The UPQ-D Series rigid removable rain hood is easily attached and removed with the included four screws (Figure 31).

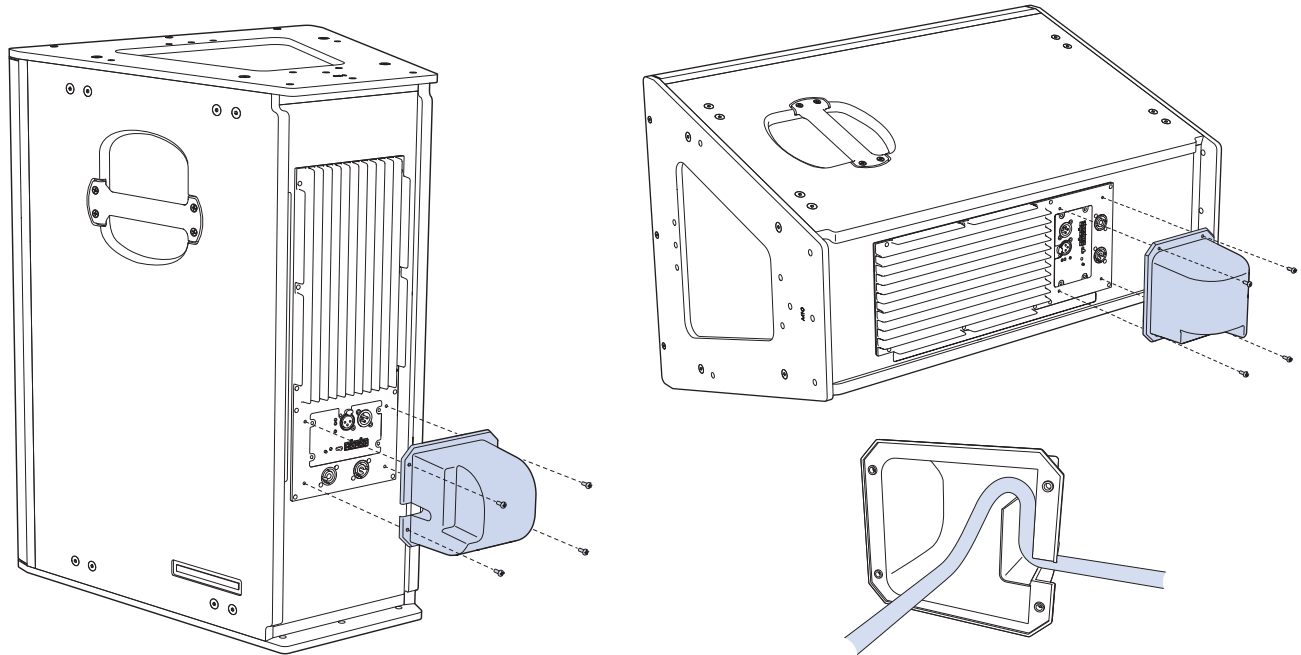





Figure 31: UPQ-D Series with rigid rain hood in Vertical Orientation (left), Horizontal Orientation (top right) and Interior Cable Routing (bottom right)

To attach the UPQ-D Series rigid rain hood:

1. Attach any required cables to the UPQ-D Series loudspeaker.
2. Carefully route the cables, so that they wrap over and down the inner rainhood wall.
3. Attach the rain hood to the user panel, and secure it to the center of the panel with its four 6-32 screws.
4. Make sure to tighten the screws to create a good seal against the user panel. The recommended torque value for the screws is 10–12 in-lb (1.1–1.4 N·m).

 **CAUTION:** There is only one proper vertical loudspeaker orientation and one proper horizontal loudspeaker orientation once the rainhood is installed. See Figure 31.

 **CAUTION:** The weather-protected UPQ-D Series loudspeaker must be mounted with a 0° tilt, or preferably with a slight down-tilt. This angle shields the driver from the elements and does not allow water to accumulate. Do not tilt the cabinet up, as the drivers and cabinet will accumulate water.

 **NOTE:** Weather-protected units using the rigid rainhood are rated IPX4 for water intrusion.

FOLDABLE RAIN HOOD

The UPQ-D Series foldable rain hood is installed on the unit when shipped. Four screws secure its frame permanently into place (Figure 32). When using the rainhood, the loudspeaker has only one possible vertical and one possible horizontal position, as all cables must exit from the lower end of the loudspeaker.

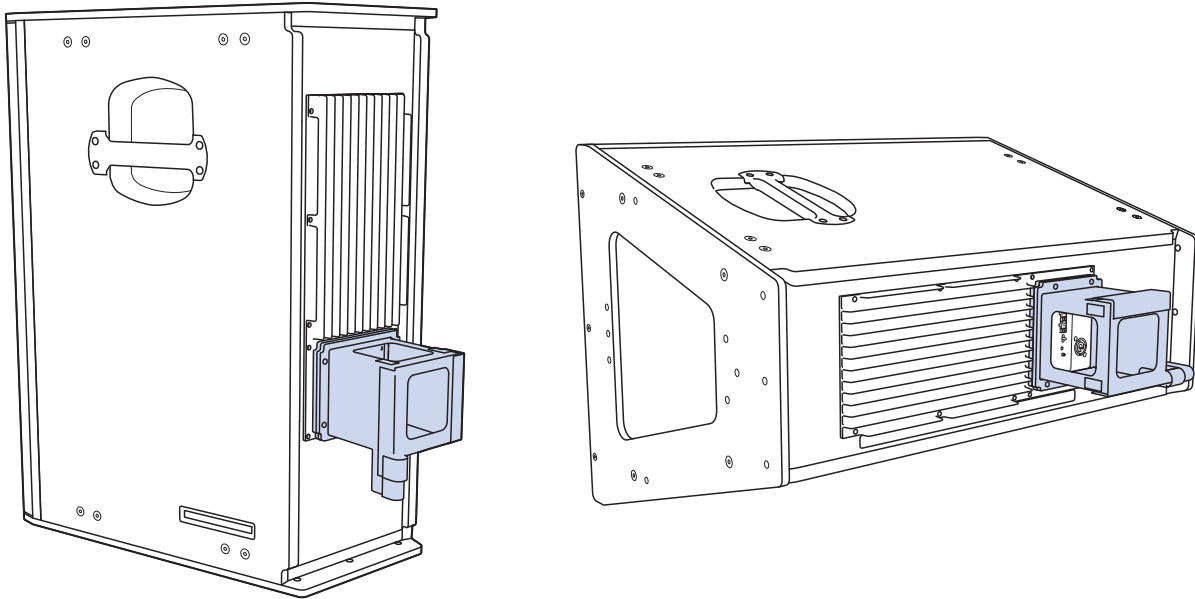

Figure 32: UPQ-D Series with foldable rain hood in vertical (left) and horizontal (right) orientations

To use the UPQ-D Series foldable rain hood:

1. Detach the Velcro straps and extend the rain hood.
2. Lift the front flap.
3. Attach any required cables to the UPQ-D Series loudspeaker.

The clear windows allow easy location of the connectors on the user panel.

4. Secure the cable protector with the Velcro attachments.
5. Secure the front flap Velcro edges.
6. Secure the flap on the right/top side of the speaker over the front flap.
7. To stow the rain hood, reverse the steps.

CAUTION: The weather-protected UPQ-D Series loudspeaker must be mounted with a 0° tilt, or preferably with a slight down-tilt. This angle shields the driver from the elements and does not allow water to accumulate.

CAUTION: The UPQ-D Series loudspeaker must be oriented so that the cord exits at the bottom of the rainhood. Use care when installing the loudspeaker to ensure the rainhood is positioned to work properly when unfolded.

APPENDIX C: UPQ-D SERIES SPECIFICATIONS



UPQ-D SERIES ACOUSTICAL, ELECTRICAL, AND PHYSICAL SPECIFICATIONS

ACOUSTICAL			
	UPQ-D1	UPQ-D2	UPQ-D3
Operating Frequency Range	55 Hz – 18 kHz	55 Hz – 18 kHz	55 Hz – 18 kHz
	Note: Recommended maximum operating frequency range. Response depends on loading conditions and room acoustics.		
Frequency Response	58 Hz – 18 kHz ± 4 dB	61 Hz – 16.5 kHz ± 4 dB	57 Hz – 18 kHz ± 4 dB
	Note: Measured free field with 1/3 octave frequency resolution at 4 meters.		
Phase Response	80 Hz to 18 kHz $\pm 45^\circ$	80 Hz to 18 kHz $\pm 45^\circ$	80 Hz to 18 kHz $\pm 45^\circ$
Linear Peak SPL	135.5 dB with crest factor >17 dB (M-noise) , 132 dB (Pink Noise), 135 dB (B-noise)	138 dB with 19 dB crest factor (M-noise) , 134.5 dB (Pink Noise), 137 dB (B-noise)	135 dB with crest factor >17 dB (M-noise) , 132 dB (Pink Noise), 134 dB (B-noise)
	<p>Note: Linear Peak SPL is measured in free-field at 4 m referred to 1 m. Loudspeaker SPL compression measured with M-noise at the onset of limiting, 2-hour duration, and 50-degree C ambient temperature is < 2 dB.</p> <p>M-noise is a full bandwidth (10 Hz–22.5 kHz) test signal developed by Meyer Sound to better measure the loudspeaker’s music performance. It has a constant instantaneous peak level in octave bands, a crest factor that increases with frequency, and a full bandwidth Peak to RMS ratio of 18 dB. The presence of a greater-than (>) symbol with regard to crest factor indicates it may be higher depending on EQ and boundary loading.</p> <p>Pink noise is a full bandwidth test signal with Peak to RMS ratio of 12.5 dB.</p> <p>B-noise is a Meyer Sound test signal used to ensure measurements reflect system behavior when reproducing the most common input spectrum, and to verify there is still headroom over pink noise.</p>		
Coverage	80° H x 50° V (–6 dB) 100° H x 60° V (–10 dB)	50° x 50° (–6 dB) 60° x 60° (–10 dB)	80° x 80° (–6 dB) 100° x 100° (–10 dB)
TRANSDUCERS			
Low Frequency	One high-power 15-inch cone driver; 2 Ω nominal impedance		
High Frequency	One 4-inch diaphragm compression driver; 8 Ω nominal impedance		
AUDIO INPUT			
Type	Differential, electronically balanced		
Maximum Common Mode Range	± 15 V DC, clamped to earth for voltage transient protection		
Connectors	XLR 3-pin female input with male loop output; optional XLR 5-pin connector to accommodate both balanced audio and RMS signals.		
Input Impedance	10 k Ω differential between pins 2 and 3		
Wiring	Pin 1: Chassis/earth through 1 k Ω , 1000 pF, 15 V clamp network to provide virtual ground lift at audio frequencies Pin 2: Signal + Pin 3: Signal – (optional polarity reversal switch) Case: Earth ground and chassis Note: Pins 4 and 5 (RMS) only included with XLR 5-pin connector that accommodates both balanced audio and RMS signals.		
Nominal Input Sensitivity	0 dBV (1 V rms) continuous average is typically the onset of limiting for noise and music		
Input Level	Audio source must be capable of producing +20 dBV (10 V rms) into 600 Ω to produce maximum peak SPL over the operating bandwidth of the loudspeaker		

AMPLIFIER			
Type	Two-channel, open-loop, Class D		
Total Output Power	2250 W peak Note: Peak power based on the maximum unclipped peak voltage the amplifier will produce into the nominal load impedance.		
THD, IM TIM	<.02%		
Cooling	Convection		
AC POWER			
Connectors	powerCON 20 input with loop output		
Automatic Voltage Selection	90–265 V AC, 50–60 Hz		
Safety Agency Rated Operating Voltage	100–240 V AC, 50–60 Hz		
Turn On/Turn Off Points	90 V AC turn-on, no turn-off; internal fuse protection above 265 V AC		
Current Draw			
Idle Current	0.27 A rms (115 V AC); 0.25 A rms (230 V AC); 0.29 A rms (100 V AC)	0.27 A rms (115 V AC); 0.25 A rms (230 V AC); 0.29 A rms (100 V AC)	0.27 A rms (115 V AC); 0.25 A rms (230 V AC); 0.29 A rms (100 V AC)
Maximum Long-Term Continuous Current	2.0 A rms (115 V AC); 1.0 A rms (230 V AC); 2.3 A rms (100 V AC)	2.0 A rms (115 V AC); 1.0 A rms (230 V AC); 2.3 A rms (100 V AC)	2.0 A rms (115 V AC); 1.0 A rms (230 V AC); 2.3 A rms (100 V AC)
Burst Current	3.7 A rms (115 V AC); 1.9 A rms (230 V AC); 4.3 A rms (100 V AC)	3.6 A rms (115 V AC); 1.8 A rms (230 V AC); 4.1 A rms (100 V AC)	3.8 A rms (115 V AC); 1.9 A rms (230 V AC); 4.4 A rms (100 V AC)
	Note: AC power cabling must be of sufficient gauge so that under burst current rms conditions, cable transmission losses do not cause the loudspeaker's voltage to drop below the specified operating range.		
Maximum Instantaneous Peak Current	8.2 A rms (115 V AC); 4.2 A rms (230 V AC); 9.3 A rms (100 V AC)	7.8 A pk (115 V AC); 4.0 A pk (230 V AC); 9.1 A pk (100 V AC)	8.4 A pk (115 V AC); 4.1 A pk (230 V AC); 9.7 A pk (100 V AC)
Inrush Current	<20 A peak	<20 A peak	<20 A peak
RMS NETWORK (OPTIONAL)			
	Two-conductor twisted-pair network that reports all operating parameters of amplifiers to system host computer.		
PHYSICAL			
Dimensions	W: 19.00 in (483 mm) x H: 28.15 in (715 mm) x D: 18.18 in (462 mm);		
Weight	95 lb (43 kg)		
Enclosure	Premium multi-ply birch with slightly textured black finish		
Protective Grille	Powder-coated, hex-stamped steel with black mesh		
Rigging	Aluminum end plates on top and bottom with metric M10 threaded points; integral 1-1/2 in (38 mm) pole mount receptacle on bottom		

ENVIRONMENTAL	
Operating Temperature	0 °C to +45 °C
Non Operating Temperature	-40 °C to +75 °C
Humidity	To 95% at 45 °C (non-condensing)
Operating Altitude	To 5,000 m (16,404 ft)
Non Operating Altitude	To 12,000 m (39,000 ft)
Shock	30 g 11 msec half-sine on each of 6 sides
Vibration	10 Hz – 55 Hz (0.010 m peak-to-peak excursion)

3K59 OR 3KJB COMMERCIAL AUDIO SYSTEM

UPQ-D1/D2/D3 LOUDSPEAKER DIMENSIONS

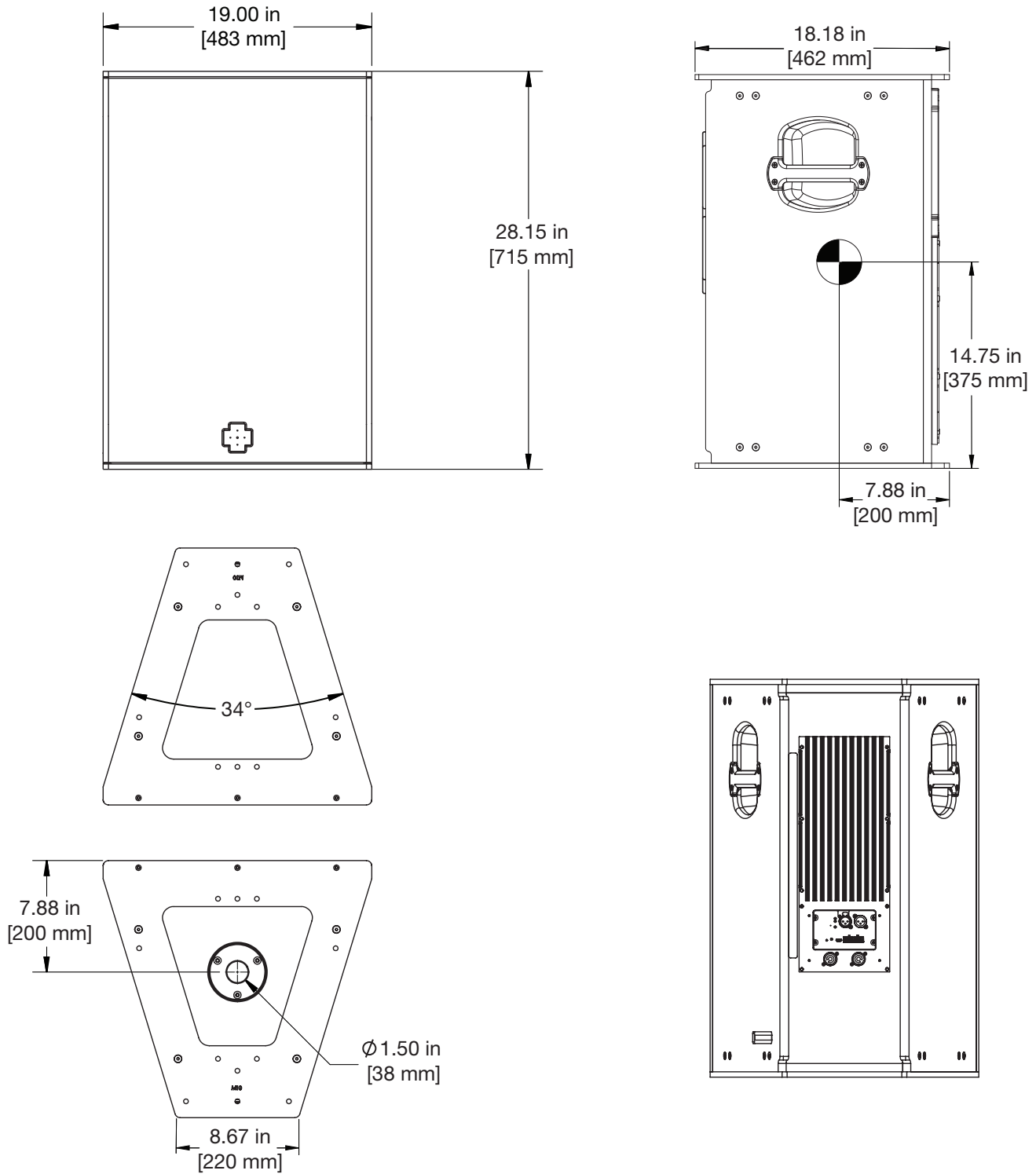

Figure 33: UPQ-D1/D2/D3 Loudspeaker Dimensions

UPQ-D1/D2/D3 WITH RAIN HOOD LOUDSPEAKER DIMENSIONS

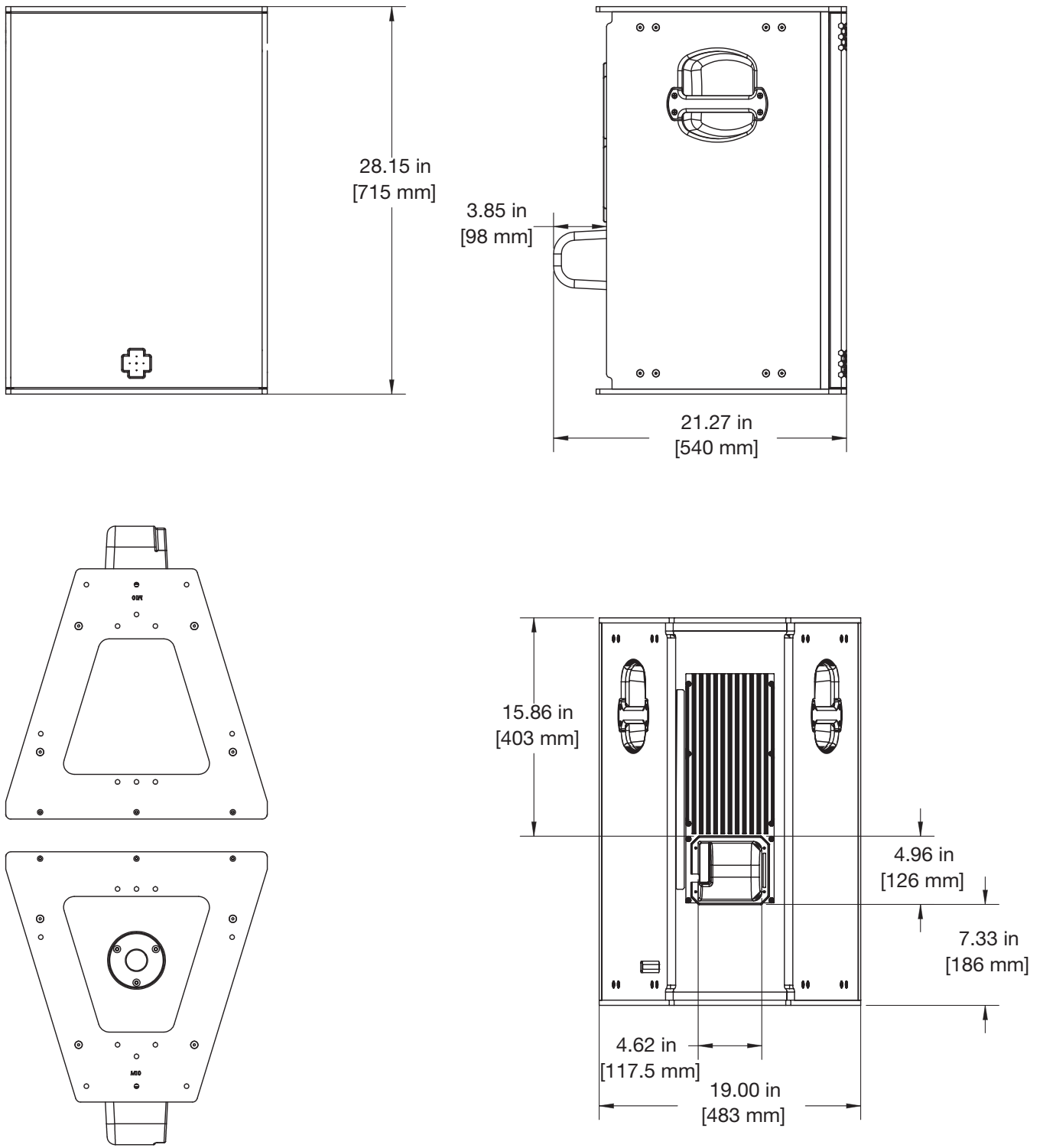

Figure 34: UPQ-D1/D2/D3 Loudspeaker with Rain Hood Dimensions





Meyer Sound Laboratories Inc.
2832 San Pablo Avenue
Berkeley, CA 94702

www.meyersound.com
T: +1 510 486.1166

© 2019
Meyer Sound Laboratories Inc. All rights reserved.
UPQ-D1/D2/D3 Operating Instructions PN 05.291.005.01 A